



Enhancing students' experiences in music composition through music notation software

Pan-hang B. Tang, *Deakin University (Australia), China Hong Kong*

Abstract

A project was undertaken in a Hong Kong primary school to investigate the role of music notation software in teaching music composition. The project was divided into three stages. During the first stage, appropriate hardware equipment and software applications were installed in the school music room, and four teaching plans were developed on the models and strategies derived from findings in the local and international literature. During the second stage, these teaching plans were implemented in Grade One, Grade Three, Grade Five and Grade Six classes of the school. During the third stage, the effectiveness of these teaching activities was evaluated by comparing the experiences from the second stage to the corresponding findings from similar projects undertaken in other Hong Kong primary schools, as well as to findings from the international literature. The results demonstrated that the visual and audio stimulation created by computer-based technology can motivate students to successfully engage in music composition. Moreover, computer-based technology provides an opportunity for students to compose music in an atonal idiom. However, a large number of students were unable to demonstrate the concept of structural design in their musical products, and one of the findings from this investigation was that teachers need to be more purposeful in their teaching by directing students to employ the technique of repetition of interesting musical fragments or phrases in order to achieve a sense of unity in their pieces.

Introduction

More than twenty years ago when I was still a primary school student in Hong Kong, music activities that I experienced were limited to singing and rhythm clapping. Instrumental playing and aural training were occasionally introduced in class, but I felt bored with the music class and I had little or no interest in the subject of music at all. It is hard to believe that I have become a primary school music teacher today. When I became a secondary school student, I had more opportunities to experience music. My secondary school music teacher had incorporated various musical activities, such as listening and music appreciation, into the regular music curriculum. I could listen to many famous musical pieces from all over the world and from different eras. At that time, I began to feel more enthusiastic about music and eventually I aspired to become a great composer. However, no music composition learning activities had ever been introduced in my school. The only way for me to learn to compose music was to seek help from outside professional musicians. Under the guidance of my private music teacher, I completed my first set of piano pieces and a song for soprano with piano accompaniment before progressing on to tertiary music education. Since graduating from university with a Master's degree in music composition, I have been working as a primary school music teacher and have been teaching my students to compose music.

Not every school music teacher in Hong Kong today, or in the past, possesses the skills to teach students how to compose music. According to research by Leung (2002, p147), only an average of 5.5% of music lessons implemented in junior secondary schools involved creative music making activities. One reason for the lack of music composition activities being taught in Hong Kong schools was that, before the return of Hong Kong to the sovereignty of Mainland China that took place in June 1997, both primary and secondary school music curricula in Hong Kong were based on singing, instrumental playing, music appreciation and music reading, while music composition activities were considered 'optional' (Curriculum Development Committee 1987, p.9). Guidelines for assisting music teachers to implement music composition activities in their teaching were noticeably absent. Besides, according to



Lai and Yip (2000), most primary school music teachers in Hong Kong used music textbooks as the main source of teaching materials. As less than 10% of the content in all Hong Kong primary music textbooks was related to creative music making activities (Lai and Yip 2000, p.418), resources to assist primary school teachers to implement such activities in class were very limited. Moreover, as summarized by Leung and McPherson (2002), the lack of creative music making activities in Hong Kong schools was also caused by the lack of suitable equipment, space, and professional training offered for teachers (p.67).

Many Western and local music educators have recognized the role of computer-based technology in promoting effective teaching and learning of music composition. Beckstead (2001) believes that students can explore sound qualities in the virtual environment created by computer-based technology. Besides, many researchers have argued that computer-based technology helps students to compose music as it allows playback of their musical ideas instantly without the need for students to develop proficient instrumental playing skills as a prerequisite to realizing their musical ideas through instrumental performance (Bamberger 1973, Bissell 1998, Stevens 1991, Macdonald and Byrne 2002, Ellis 1990). Moreover, students are able to share their musical works with others through computer-based communication technology (Reese 1998, Creative Arts and Home Economics Section [Music] Advisory Inspectorate Division 1999). Given such evidence in support of this medium, I believe that computer-based technology is a useful tool that can assist Hong Kong primary school music teachers in facilitating music composition activities in class.

A school-based research project was undertaken by a colleague and myself in order to further investigate the role of computer-based technology in assisting primary school children to engage with music composition. The school that we worked at is a primary school in Hong Kong. The project was divided into two parts. The aims of the first part were to find out how music notation software may be utilized to teach music composition in our school environment, as well as to determine what quality and variety of music compositions our students were capable of achieving. The second part of the project was to find out the role of computer-based technology in teaching music theory. However, this article will focus exclusively on reporting the outcomes from the first part of the project.

Research methodology

The principal research method employed in this project was collaborative action research. According to Carr and Kemmis (1983), the aim of action research is 'to improve their [action researchers'] own educational practices, their understandings of these practices, and the situations in which they practice' (p.180). Unlike an observer-researcher who aims to identify key issues in a classroom context by observation, an action researcher takes a more active role in planning, implementing and evaluating classroom practice. Through a 'self-reflective spiral approach' (p.162) to planning, acting and observing, an action researcher can enhance his/her existing knowledge, skills and understanding of particular educational practices.

Based on the definition of action research given above, I conducted the school-based project as a three-stage process of *Planning*, *Implementation* and *Evaluation*. During the *Planning* stage (September to December 2004), appropriate hardware equipment and software applications were installed in our music classroom. Then, my colleague and I designed a series of teaching activities based on the teaching models and strategies derived from the local and international literature. During the *Implementation* stage (January to July 2005), we implemented these teaching activities in class, engaged in on-going reflection on these teaching strategies, and revised and improved the procedures employed in our teaching activities. During the *Evaluation* stage (July 2005), two main methods were employed to assess the effectiveness of our teaching activities. The motivation of students engaging in music composition was evaluated by a group-interview of students. Their comments were compared with the corresponding results of similar projects conducted in other Hong Kong primary schools. Meanwhile, the quality of the students' products was assessed using general music analysis techniques, and was also compared with the findings reported in similar



projects that have taken place in other countries. Through our project, we hope to provide additional information for other primary school teachers wishing to utilize computer-based technology in teaching music composition, as well as to demonstrate ways which can improve teachers' professional knowledge and skills in integrating computer-based technology into the teaching of music composition.

Planning

Installing appropriate hardware equipment and selecting suitable application software

There is a large variety of music notation software programs available in the marketplace. Many of them work in a similar way with more or less the same functions. They are developed with a user-friendly interface and are reasonably priced. Some are even downloadable from the Internet free of charge. For this reason, almost any kind of music notation software is suitable to be employed in our project. However, we chose a music notation software program called *Music Time Deluxe* as the main tool for assisting in our teaching activities, because this application software is easy to use and the price is reasonable.

Seven workstations (one for the teachers and six for the students) were installed in the music classroom resulting in an access ratio of four students to one computer. Figure 1 below shows the music classroom setting. All seven workstations were connected to a network with a projection system and an inkjet printer. Figure 2 shows the components of each workstation which consists of a computer hard disk, a monitor, a CD/DVD-ROM drive, a floppy disk drive, a sound card, a pair of speakers, a typing keyboard, and a MIDI keyboard.

Figure 1
Classroom Setting

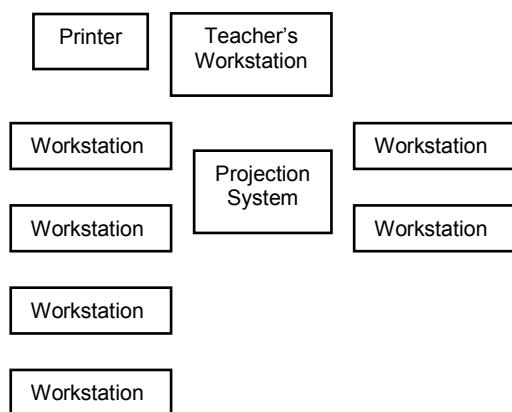
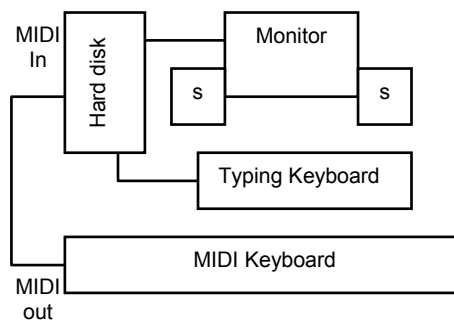

Figure 2
Workstation Setting



Funding for hardware equipment and the music notation software was provided by the Quality Education Fund (QEF). The QEF was established in 1997 by the Government of the Hong Kong Special Administrative Region of the People's Republic of China for the purpose of sponsoring projects that promote quality education in Hong Kong (Education Commission and Education and Manpower Bureau 2004). Eligible sectors include kindergartens, primary schools, secondary schools, tertiary institutions and special education organizations. From 1998 to 2004, 1,239.4 million Hong Kong Dollars had been allocated to fund projects for promoting the application of information technology in education (Education Commission and Education and Manpower Bureau 2004). Thus, the QEF is a main source of funding for schools to establish technology-assisted teaching facilities, including computer-assisted



music teaching rooms.

Designing teaching plans based on models advocated in the local and international literature
Four different teaching plans were developed respectively for our school's Grade One students (aged 6 to 7), Grade Three students (aged 8 to 9), Grade Five students (aged 10 to 11) and Grade Six students (aged 11 to 12). The teaching plans were developed on the bases of two principal learning theories. The first one is the cognitive-developmental model, which was developed in early 1960's by Piaget, Bruner, etc. Instead of being transferors of knowledge as in the traditional way of teaching, teachers using this pedagogy act as facilitators to help students to construct knowledge and skills according to the students' needs and preferences. In our case, we taught students to compose music by providing them with an opportunity to learn in an open environment, in which they could explore sound sonorities freely with the music notation software. The advantage of using such a strategy is that students do not have to first develop highly proficient skills in keyboard performance or in using the computer before they can compose music. Our contentions were that students' creativity can be greatly enhanced by using music composition software and that the resultant compositions would tend to be more musically expressive.

Another principal learning theory is the Sequential Teaching for Creative Music Making (STCMM) developed by Leung (2002). The STCMM is a pedagogical framework for teachers to implement music composition activities in the teaching environment in Hong Kong schools. The framework divides the music composition learning process into four stages (see a representation of this in Table 1 below). The first stage is 'Motivation'. During this stage, teachers should provide sufficient motivation to encourage their students to compose a musical piece. Also, teachers should give clear instructions by providing students with the necessary skills and knowledge as well as the appropriate criteria for the creative task.

Table 1
Model of Sequential Teaching for Creative Music Making (STCMM)

Teacher Behaviour	Learning Process	Student Behaviour
Raise a musical issue Provide literal/audio/visual stimuli Assign the creative task Provide necessary knowledge and skills through listening and performing Set the criteria for the task	Motivation ↓	Be motivated Understand the task Grasp the related knowledge and skills
Provide music models Inspect the class work Facilitate the creative process Provide feedback to students	Imitation/Association ↓	Sound exploring Improvise Group discussion Record/notate their compositions
Facilitate the rehearsals Coach the rehearsals	Inspiration ↓	Decision making Finalise their works Rehearse
Evaluate the creative works and performance with the given criteria Discuss with the whole class Suggest ways to improve the piece and the performance Reflect on the teaching process	Feedback ↓	Perform their creative works Listen to and appraise the works Discuss with the teacher and the classmates Reflect on the creating process

(Adapted from Leung 2002, p. 239)

The second stage, 'Imitation / Association', best occurs when students are in a student-



centred or student-directed teaching/learning situation. Before students are asked to compose, they should be given a set of musical pieces to imitate. However, mere imitation is not an act of authentic creation, so teachers should encourage students to employ music composition skills and techniques used in famous musical works in their own musical pieces. This process is defined as 'Association'.

The third stage of the STCMM is known as 'Inspiration'. During this stage, students have to make decisions about composing their musical pieces. Teachers should assist students to rehearse their musical pieces and provide opportunities for them to perform their pieces in class, at school concerts or even at public concerts.

The final stage of the STCMM is called 'Feedback'. After students' pieces are performed, teachers, students and their class peers reflect upon, discuss and evaluate the music compositions. The purpose of the discussion is to improve students' composing skills and to expand their knowledge and understandings of the music making process. After the discussion, students should hopefully be able to create more complex and sophisticated pieces on subsequent occasions.

Implementation

The following four teaching plans (outlined in Tables 2-4 below) were designed for Grade One students (aged 6 to 7), Grade Three students (aged 8 to 9), Grade Five students (aged 10 to 11) and Grade Six students (aged 11 to 12). There were four Grade One and Grade Three classes respectively, and two Grade Five and Grade Six classes respectively in the school. The teaching plans for Grade One and Grade Three students were designed and implemented by myself, while plans for Grade Five and Grade Six students were designed and implemented by my colleague. After each lesson, we reflected on the teaching methods employed, and revised the procedures before implementing them again in another class. Below are the final versions of these lesson plans. These plans are designed to correspond to the four stages suggested by the STCMM.

Table 2

Teaching plans for Grade One students

<i>Grade One</i>	
Topic:	Music Composition Competition
Objective:	To teach students to compose a melody with crochets and quavers
Outline:	Students in each class will compose a melody together. After all classes complete their melodies, students will listen to the melodies composed by other classes and will vote for the best one. The class which receives the most votes wins.
Number of Lessons:	2
Previous Knowledge:	Students are able to identify crochets and quavers, and to use the mouse as a computer input device.
Teaching Procedure:	
<u>Lesson 1</u>	
<u>Motivation</u>	
1)	Teacher demonstrates how crochet notes and quaver notes are notated in the <i>Music Time Deluxe</i> .
2)	Teacher assigns the task: each student contributes either a crochet or two quavers to make up a melody.
3)	Teacher motivates the students by indicating that it is a music composition competition.
<u>Imitation/Association</u>	
1)	Each student inserts a rhythmic element, either a crochet or two quavers, to the piece at teacher's computer.
2)	Teacher helps students by asking, 'Which rhythm do you like, one crochet or two quavers?'
3)	Teacher provides more assistance to any student who is not sure about how to insert notes with the mouse.
4)	Teacher plays the melody each time after new notes are added.
5)	Teacher asks the students which part of the melody they like the most.
6)	Teacher uses the 'copy and paste' function to repeat the part that the students like most in order to bring unity to the melody.



Inspiration

- 1) Students complete the melody.
- 2) Teacher plays the whole melody on the computer when it is completed.

Lesson 2

Feedback

- 1) Teacher plays the melodies composed by all other Grade One classes.
- 2) Teacher asks the students which melody they like the most and why they like it.
- 3) Teacher asks the students to vote for the best piece, excluding theirs.
- 4) The class that receives most votes wins.

Table 3

Teaching plans for Grade Three students

Grade Three

Topic: Our music story

Objective: To compose a set of melodies as the background music for a story the students have created.

Outline: The whole class is divided into groups of four students. Each group has to compose a set of songs, which are used as the background music of a story they created.

Number of Lessons: 8

Previous Knowledge:

- 1) Basic music theory, including rhythm, pitch, meter and key signatures.
- 2) Basic abilities in operating a computer, such as mouse-click, and drag-and-drop.
- 3) Basic abilities in using the music notation software, such as setting-up of a MIDI device.

Teaching Procedure:

Lesson 1

Motivation

- 1) Students are divided into groups of four.
- 2) Students are required to compose a set of songs as the background music for a story they have created.
- 3) Teacher provides examples as stimulation.
- 4) Teacher discusses the examples with students before the task begins.

Lesson 2 – 6

Imitation/Association, Inspiration

- 1) Students discuss with their group members about the task.
- 2) They create a story together.
- 3) They explore the sound sonorities at the computer workstation.
- 4) They discuss what kinds of sound sonorities are suitable as the background music for their story.
- 5) Teacher inspects the class works.
- 6) Teacher provides assistance in computer skills and/or musical skills according to individual students' needs.
- 7) Teacher helps students by asking open-ended questions, such as:
 - i) to imply the answer, 'Check the *Measure* Menu, you may be able to change the time signature from there.'
 - ii) to provide more options, 'Did you try this? Which one do you think is better?'
- 8) Teacher gives immediate feedback to students.
- 9) Teacher praises the groups who do well.
- 10) Students make the decision to finalise their musical pieces.
- 11) Students combine their musical piece with the story to make a story book.

Lesson 7 –8

Feedback

- 1) Each of the groups tells their story to the class, with the musical pieces they composed as the background music.
- 2) Teacher and students discuss the performance of each group.
- 3) With the guidance of the teacher, students show appreciation and make criticism of other students' works.

Table 4

Teaching plans for Grade Five students



Grade Five

Topic: Making a melody
 Objectives: To compose a melody on a single staff
 Outline: Students are divided into groups of four and compose a 16-bar melody based on their preferences.
 Number of Lessons: 6
 Previous Knowledge:

- 1) Basic music theory, including rhythm, pitch, meter and key signatures.
- 2) Basic abilities in operating a computer, such as mouse-click, and drag-and-drop.
- 3) Basic abilities in using the music notation software, such as setting-up of a MIDI device.

Teaching Procedure:

Lesson 1

Motivation

- 1) Students are divided into groups of four.
- 2) Students are required to compose a 16-bar melody based on their preferences.
- 3) Teacher provides examples as stimulation.
- 4) Teacher discusses the examples with students before the task begins.

Lesson 2 – 5

Imitation/Association, Inspiration

- 1) Students should discuss the task with their group members.
- 2) They explore the sound sonorities in the computer workstation.
- 3) Teacher inspects the class work.
- 4) Teacher provides assistance in computer skills and/or musical skills according to individual students' needs.
- 5) Teacher helps students by asking open-ended questions and giving comments.
- 6) Teacher praises the groups that do well.
- 7) Students make the decision to finalise their musical pieces.

Lesson 6

Feedback

- 1) Teacher and students listen to the music pieces composed by each group. They discuss the quality of each musical piece.

Table 5

Teaching plans for Grade Six students

Grade Six

Topic: Making a musical piece
 Objectives: To compose a musical piece with a given starting phrase on the piano staff
 Outline: Students are divided into groups of four. Students in each group compose a musical piece on the piano staff with a given melodic motif as the starting phrase.
 Number of Lessons: 6
 Previous Knowledge:

- 1) Basic music theory, including rhythm, pitch, meter and key signatures.
- 2) Basic abilities in operating a computer, such as mouse-click, and drag-and-drop.
- 3) Basic abilities in using the music notation software, such as setting-up of a MIDI device.

Teaching Procedure:

Similar to those of the Grade Five teaching plan.

Evaluation

Discussion of students' motivation to compose music with computer-based technology

Projects similar to the present one have been conducted in various Hong Kong primary schools. According to the Quality Education Fund Cyber Resource Center (Quality Education Fund 2003), another thirteen primary schools have received financial support from the QEF to conduct similar projects. The Quality Education Fund Cyber Resource Center documents the schools' proposals, summaries, and final reports on the Internet. According to their final reports (Quality Education Fund 2003), most of these thirteen primary schools have elicited students' opinions through questionnaire surveys. Of these thirteen schools, four have



provided detailed descriptions of their survey results. All these four schools found out that the majority of their students have become increasingly more interested in making music compositions with computer-based technology (see Table 6 below).

Table 6

Summary of questionnaire surveys conducted by other QEF-supported primary schools

	School A	School B	School C	School D
Total number of students participated in the questionnaire survey	1458	615	450	20
Total number of students that agreed computer-based technology motivates them to make composition	1376	561	No data provided	14
Percentage of students that agreed computer-based technology motivates them to make composition	94.73%	91.22%	75%	70%

We used a different means of data gathering and found that the results were similar to those reported in other projects. A group interview was conducted to elicit our students' opinions about their motivation to engage with making music composition. One student was randomly selected from each of the Grade One to Grade Six classes so that there was a total of 18 students who participated in the group interview. The Grade Two and Grade Four students were invited to participate because the interview also included aspects about the second part of the project mentioned previously, i.e. the learning of music theory. The Grade Two and Grade Four students were asked to give their opinions in the second part of the interview. Although the students did not learn to utilize computer-based technology to compose, they were encouraged to provide comments about this issue. The interview was conducted in Cantonese and was tape-recorded. The interview was then transcribed and translated into English as follows:

- Teacher: How do you use *Music Time Deluxe*?
- Student (3B): I choose musical notes from the main palette, and then hear back my melody.
- Student (4A): I can drag and drop notes onto the staff by mouse.
- Student (3A): I can input musical notes onto the staff by playing music on the MIDI keyboard.
- Student (4B): I can hear back the music that I have input into the computer.
- Teacher: Do you enjoy making music composition with a computer?
- Student (6A): Yes, I can learn to make music composition with this software [*Music Time Deluxe*].
- Student (3B): This software allows me to add colours to the musical notes. It is fun.
- Student (2B): I want to compose a song with a computer. It must be interesting if I can sing my song after I have printed it out.
- Student (4A): I did not learn to use a computer to compose music. I just learned to input musical notes with this software application. It is boring to use computer in this way. I prefer to use a computer to make music composition.
- Teacher: How do you make music composition without this software [*Music Time Deluxe*]?
- Student (2B): By reading books and writing notes on manuscripts.
- Teacher: Does this software help you to make music composition?
- Student (3D): Yes, it is better to learn to compose music with this software because I can hear back my composition.

Similar to the result from the questionnaire surveys conducted by the other Hong Kong primary schools (Quality Education Fund 2003), we found that most of their children in our interview groups agreed that they enjoyed composing music with a computer. They enjoyed listening to their musical ideas through the playback function of the music notation software, and creating a colourful musical piece with the colour-changing function of the software. Amabile (1983) provides an explanation of how computer-based technology can help to motivate children. She discussed the role of intrinsic motivation and external stimulation in the creativity thinking process. She concurred that 'the highest forms of creativity are generated under conditions of freedom from control' (p.75), and the 'freedom from extrinsic constraint will enhance creativity' (p.76). In other words, the complex process of creative thinking can only occur when an individual is intrinsically motivated to perform a creative task. In addition, Amabile suggests that external stimulation might influence and affect the extent of an



individual's intrinsic motivation. Accordingly, students assisted by computer-based technology are motivated to engage in music composition because they are stimulated by the audio and visual effects of the computer, such as the colour-changing function (visual stimulation) and the playback function (audio stimulation). Music teachers can use these functionalities of computer-based technology as an additional tool to motivate students to compose.

Discussion of students' musical products

A total of eighty-five music compositions were collected from this project. All the musical pieces were analyzed in terms of tonality, accidentals, and structure. A tabulation of the analysis is presented in Table 7 below.

Table 7

Detailed analysis of musical products composed by children of different grades

	Grade One	Grade Three	Grade Five	Grade Six
Total number of musical pieces collected	4	53	9	19
Tonality				
Number of tonal musical pieces collected	0	13	0	11
Major Key	0	11	0	11
Minor Key	0	2	0	0
Number of atonal musical pieces collected	4	40	9	8
Note-clusters	0	11	0	4
Fast-running patterns	0	15	3	4
Melody with wide leaps larger than an octave	4	14	6	0
Use of Accidentals				
Number of pieces containing accidentals which imply modulation	0	1	0	1
Structure				
Total number of pieces constructed with organization	4	20	1	7
Repetition of motives	0	8	1	2
Organized phrase structure	4	12	0	5
Total number of pieces constructed without organization	0	33	8	12

Figure 1 (below) is the notation of a musical piece composed by a group of four Grade Six students. While one of them had obtained an ABRSM Grade 5 Piano Certificate, other members of the group had not received any formal training in musical instrument performance. The piece is written in major key and a melodic motif frequently appears which brings a sense of unity to the piece. The motif (in box 1) consists of an ascending octave-leap, and is followed by a descending perfect 5th. The higher C of the motif is elongated when it reappears the second time and the third time, while passing notes and a minim-rest are added during the last repetition.

Figure 1

An example of musical composition made by Grade Six students

The musical score is for a piano piece in 4/4 time. It consists of four systems of music. The first system is labeled '1' and shows a melody in the right hand and a bass line in the left hand. The second system is labeled '2' and '3' and continues the melody. The third system is labeled '4' and shows a change in texture with a cluster in the left hand. The fourth system continues the melody and bass line.

There were more pieces written in major than minor keys as shown in Table 7. Only two musical pieces are written in minor keys. The piece shown in Figure 2 (below) was composed by a group of four Grade Three students. One of them had obtained the ABRSM Grade Four Piano Certificate, while the rest had obtained the Grade Two Piano Certificate. The fragment marked in brackets is the motif which is developed through sequence. Besides the use of a minor key, the textural change at bars 12 to 13 is another unique element that cannot be found in other students' compositions.

According to Table 7, there was a tendency for our students to compose atonal pieces. Three types of atonal music composition were identified according to the characteristics of this musical style: note-clusters, fast running patterns, and melody with wide-leaps larger than an octave. Figure 3 shows examples of these three types.

It was also found that boys demonstrate a greater tendency to create atonal music than girls. During the lessons, several boy-groups said that they enjoyed creating atonal music compositions. They always laughed at the 'noises' they made. Furthermore, students with less musical skills and knowledge were more likely to create atonal music. The more musical knowledge the students had, the more skills they could apply to manipulate the tonality of their pieces. The most experienced students could even employ modulation in their pieces. Figure 4 is a musical piece composed by a group of three Grade Six students. One of them had obtained the ABRSM Grade 6 Piano Certificate. Another had obtained the Grade 4 Piano Certificate, while yet another had obtained the Grade 3 Clarinet Certificate. The piece they composed starts in C Major but the note A⁰ in bar 6 suggests the changing of key to the tonic

minor, C minor.

Figure 2

An example of musical composition written in a minor key



Apart from a preference to write tonal music, students with more musical experiences showed a tendency to construct their pieces with a definitive form or structure. They organize their pieces to show a sense of unity as well as variety. The students used two different methods to structure their pieces. The first was to repeat musical motives, which have been discussed with reference to Figures 1 and 2. The other method employed was to organize their pieces with clear-cut phrases and clearly-marked cadences. Figure 5 is an example where students constructed the phrase structure in AABA form.

Figure 3

Three types of atonal music composition created by children using music notation software

Figure 3a



Note-clusters

Figure 3b

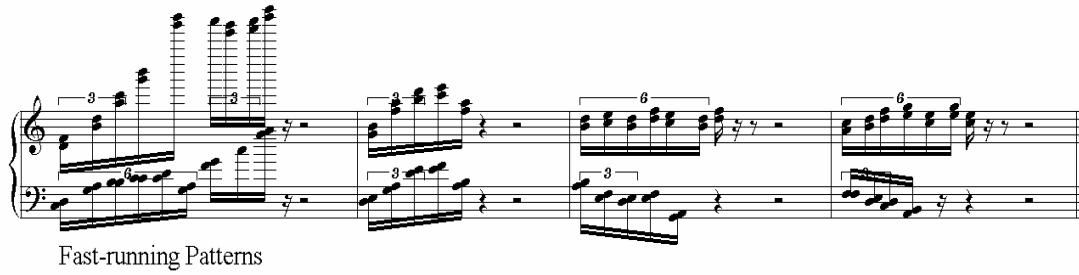

Figure 3c

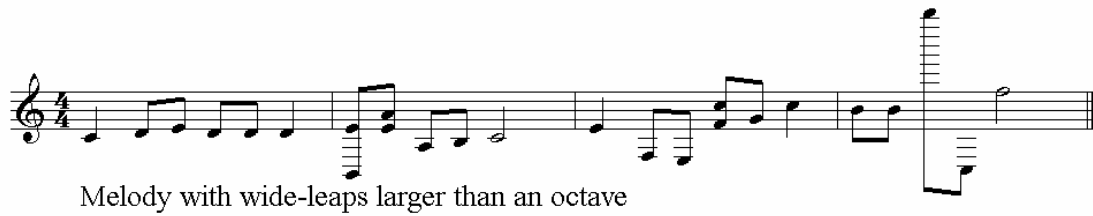

Figure 4

A music composition with modulation





An early researcher of children's composition, Doig (1941, 1942a, 1942b), designed three teaching activities to teach children (aged 6 to 16) to engage with music composition, and then analyzed the characteristics of the musical products they created. In the first activity, Doig asked her students to set a melody to a given verse. After reading the text to a group of same-aged students, she invited some of them to improvise the first phrase of the verse by singing. She wrote down various versions on the blackboard, and then asked her students to vote for the best one. Melodies for other phrases of the verse were composed in the same way. In the second activity, Doig asked her students to compose music according to a given subject. The teaching procedure developed was implemented in a way similar to the first activity, except that the students were required to create their own text. In the third activity, three tasks were given to the students. Doig first asked them to change the meter and rhythm of a given melody. Then, they were required to continue a given melodic phrase. Finally, the students had to compose either a march or a waltz.

In relation to tonality, Doig collected five pieces in the first activity and found that all five were written in major keys. Meanwhile, among the twenty-nine pieces collected in the second activity, twenty-eight were written in major keys, and one was in minor key. No atonal pieces were found in all the three activities. Many pieces composed by Doig's students were written with well established form and design such as AA', and AA'BB'. Some pieces were without a formal structure, and Doig classified these as unidentified forms, such as 'Five Phrases', and 'Miscellaneous Phrase Groups'. Based on these findings, Doig concluded that children of that age range had already developed a sense of tonality (1942b, p.252), as well as a concept to design (1942a, p.352). She considered these abilities as a natural learning process similar to 'the development of language concepts by children' (1942a, p.355). Compared to what was found by Doig, the question arises as to the reasons why our students seem to be less able to compose music with a 'sense of tonality' and a 'concept to design'. It is possible that our students had already developed such abilities, but they simply did not know how to notate the right notes in their minds into a computer. It is obviously easier to sing out one's idea than to work it out on a computer.

Another point of view was that, although computer-based technology does not favour students to compose tonal music, it makes the writing of atonal pieces easier. The note-clusters, fast-running patterns and melodies with wide-leaps larger than an octave are musical elements that are definitely far beyond the imagination of students who developed compositional skills using Doig's methods. Since the early twentieth century, atonal music has become one of the main streams of traditional classical music. Music composed by Schoenberg, Stockhausen, and Tan Dun emphasizes atonality. Therefore, in the current situation, music teachers should not discourage students who wish to compose atonal pieces.

During my study at university, I was taught to understand how classical composers brought a sense of unity and variety to their pieces, how they developed motives, and how they designed music with a recognizable formal structure. After acquiring such knowledge, I became able to apply these skills to my music composition. I am therefore uncertain that structural design is really a naturally-occurring process like the development of language as Doig suggested. On the contrary, I believe that such a concept can only be acquired through specific musical training, such as what I had received during my university study. In order to help students to develop a sense of unity, teachers should remind students to 'repeat' interesting musical fragments or phrases. After I had introduced this compositional technique to the Grade Three students in their activity, many of them began to compose with repetition of motives or melodic phrases (for an example, see Figure 5 below).

Figure 5

A music composition designed in AABA form



Conclusion

From the last decade of the twentieth century to the early twenty-first century, there has been a tremendous growth of research studies designed to explore the possibilities of and effects on utilizing computer-based technology in teaching students to compose music. Savage had conducted three investigative projects (Savage 1999, Savage and Challis 2001, Savage and Challis 2002) in which a series of music composition teaching and learning activities using different kinds of computer-based technology were trialed. The first project explored the possibility of using the *Zoom 1204* sound processor to help secondary school students to compose. The second project further explored the impact of the use of sound processors. Savage began this second project by motivating his students to make music composition by telling them the story of the fabled city of Dunwich. He then presented a musical piece to his students. The musical piece was composed by his colleague, the composer Mike Challis. Finally, the students were required to compose their own pieces with reference to the piece by Challis and the story. The third project investigated the use of digital technology in creative tasks. The software employed in the project included *Digital Performer*, *Pro Tools* and *Metasynth*. A group of secondary school students were asked to record visual and audio sample materials. The students exchanged their material with a group of young offenders. Then, both groups edited the materials by others using the software applications. All three projects were conducted in a five-stage process, including Starting Points, Experimentation, Selection, Structure, and Evaluate/Revise (Savage 2005).

After the three projects had been undertaken, Savage assessed the effects of using computer-based technology in teaching music composition. With similar findings as our



results suggest, Savage found that computer-based technology could help to motivate students to engage in music composition. In addition, he found that technology could provide a suitable environment for the students to compose music (Savage 2005, p.171). Such environment enabled his students to explore the sounds, rather than forcing them to work 'in the context of right or wrong compositional choices' (Savage 2005, p.171). In such an environment, students will be able to create their pieces with more musical expressiveness (Tang 2005).

Furthermore, Savage believed that the computer-based technology brought 'a shift of emphasis in compositional enquiry, away from thinking about melody, rhythm or harmony towards an increasing focus on dealing with the sound itself, and its intrinsic value and place in a wider music structure' (Savage 2005, p.171). Likewise (as shown in Table 7), there were more atonal pieces than tonal pieces written by our students, and there were many pieces written with sound effects, such as note-clusters and fast-running patterns, as opposed to melodic content. This 'shift' has not only changed the way in which today's children compose, but also expanded their understandings of the function and structure of music. Therefore, in turn, our teaching methods might have to change to suit the 'shift' in children's understanding of music.

With the help of computer-based technology, students participating in the project demonstrated enhanced motivation to compose. Moreover, it was found that technology can provide young children with the opportunity to compose atonal music in the same way as twentieth and twenty-first century composers. Accordingly, despite computer-based technology being such a powerful tool, teachers should not place total reliance on technologies when they engage students in music composition making activities. Teachers should always acknowledge their major role as facilitators whose task it is to assist students to acquire compositional knowledge and skills. For instance, Leung (2002) has suggested that teachers should facilitate students engaging in music composition tasks by setting criteria, providing music models as stimulation, coaching rehearsals of students' pieces, giving them feedback, etc. In this project, my colleague and I provided students with composition skills and knowledge by reminding them to repeat interesting musical fragments and materials. Without the input of teachers in this way, it would be difficult for students to achieve a successful outcome from their music compositional activities.

References

- Amabile, T. M. 1983, *The Social Psychology of Creativity*, Springer-Verlag, New York.
- Bamberger, J. 1973, 'Learning to think musically', *Music Educators Journal*, vol. 59, no. 7, pp. 53 - 57.
- Beckstead, D. 2001, 'Will technology transform music education?' *Music Educators Journal*, vol. 87, no. 6, pp. 44 - 49.
- Bissell, P. M. 1998, 'Tune in to technology', *Music Educators Journal*, vol. 85, no. 2, pp. 39 - 41.
- Bruner, J. 1967, *A Study of Thinking*, Science Editions Inc., New York.
- Carr, W. & Kemmis, S. 1983, *Becoming Critical: Education, Knowledge and Action Research*, Deakin University, Victoria.
- Creative Arts and Home Economics Section [Music] Advisory Inspectorate Division 1999, *The Application of Information Technology in the Teaching of Music, Handbook for Music Teachers*, Printing Department, 171.
- Curriculum Development Committee 1987, *Syllabuses for Primary Schools*, Government Printer, Hong Kong.
- Doig, D. 1941, 'Creative Music: I Music Composed for a Given Text', *Journal of Educational Research*, vol. 35, no. 4, pp. 263-275.
- Doig, D. 1942a, 'Creative Music: II Music Composed on a Given Subject', *Journal of Educational Research*, vol. 35, no. 5, pp. 344-355.
- Doig, D. 1942b, 'Creative Music: III Music Composed to Illustrate Given Musical Problems', *Journal of Educational Research*, vol. 36, no. 4, pp. 241-253.



- Education Commission & Education and Manpower Bureau January 2006, 'Quality Education Fund', <<http://qef.org.hk/>>.
- Ellis, P. 1990, 'Composing: New Music Technology: A New Curriculum Soundscape', in Dobbs, J. (Ed.) *Music Education: Facing the Future*, International Society for Music Education, pp. 213 - 218.
- Lai, M. T. & Yip, R. L. C. 2000, 'Content Analysis of Selected Primary Music Textbook Series', in Cheng, Y. C., Chow, K. W., Tsui, K.T. (Eds.) *School Curriculum Change and Development in Hong Kong*, The Hong Kong Institute of Education, Hong Kong, pp. 411 - 424.
- Leung, B. W. 2002, *Creative Music Making in Hong Kong Secondary Schools: The Present Situation and Professional Development of Music Teachers*, PhD thesis, University of New South Wales, New South Wales.
- Leung, B. W. & McPherson, G. E. 2002, 'Professional Composers' and Curriculum Planners' Perceptions about Creativity in Hong Kong School Music Programs', *International Journal of Music Education*, vol. 40, no. 1, pp. 67-77.
- Macdonald, R. A. R. & Byrne, C. 2002, 'Teaching Strategies in the Music Classroom: The Impact of Information and Communication Technologies', *International Journal of Music Education*, vol. 40, no. 1, pp. 44-56.
- Piaget, J. 1963, *Origins of Intelligence in Children*, Norton, New York.
- Quality Education Fund 17-6-2003, 'QEF Cyber Resource Centre', <http://qcrc.qef.org.hk/qef/result.phtml?app_no=-1&benef=2&nature_id=0&subnature_id=4&subcat_id=403&order=&fcid=&feature_id=&resource_cat_code=&resource_subcat_id=&mode=browse&lang=2>.
- Reese, S. 1998, 'Music learning in your school computer lab', *Music Educators Journal*, vol. 85, no. 3, pp. 31 - 36.
- Savage, J. 1999, 'Approaches to Composition with Music Technology in the Key Stage 3 and 4 Curriculum', *European Music Journal*, <<http://www.music-journal.com>> (*European Music Journal*)
- Savage, J. 2005, 'Working Towards a Theory for Music Technologies in the Classroom: How Pupils Engage with and Organise Sounds with New Technologies', *British Journal of Music Education*, vol. 22, no. 2, pp. 167-180.
- Savage, J. & Challis, M. 2001, 'Dunwich Revisited: Collaborative Composition and Performance with New Technologies', *British Journal of Music Education*, vol. 18, no. 2, pp. 139-149.
- Savage, J. & Challis, M. 2002, 'A Digital Arts Curriculum? Practical Ways Forward', *Music Education Research*, vol. 4, no. 1, pp. 7-24.
- Stevens, R. S. 1991, 'The Best of Both Worlds: An Eclectic Approach to the Use of Computer Technology in Music Education', *International Journal of Music Education*, no. 17, pp. 24 - 38.
- Tang, P. B. 2005, 'Teaching Musical Creativity in Hong Kong Primary Schools: A Review of the Immediate Past and the Current Situation of Teaching and Learning through Technology', in Morrison, S. (Ed.), *Proceedings for the Fifth Asia-Pacific Symposium for Music Education Research*, University of Washington, Seattle.

About the Author

Pan-hang Tang is a Hong Kong primary school music teacher and he is also teaching in the Centralized Scheme of Music Training for Senior Secondary Students and the Hong Kong Institute of Education. He is now a Ph.D. student at the Deakin University and is interested in both musical creativity and the use of computer-based technology in the teaching of music.

Contact Details

Pan-hang B. Tang (PhD student)
Faculty of Education
Deakin University (Australia)
Email: pbt@deakin.edu.au