

OLYMPUS®

*Modules described
in this manual*

SZ2-ST
WHSZ Series Eyepieces
Auxiliary Objectives
SZX-STAD1
SZH-STAD1
SZ2-FO
SZH-SG
SZH-SC

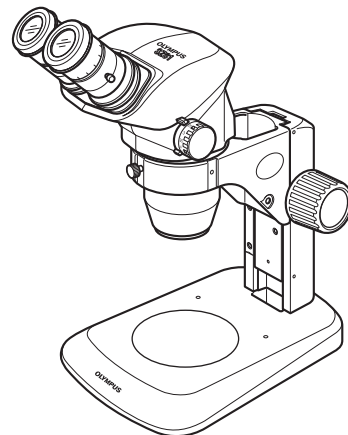

INSTRUCTIONS

SZ61/SZ61-60 SZ61TR SZ51/SZ51-60 ZOOM STEREO MICROSCOPES

CE

This instruction manual is for the Olympus Zoom Stereo Microscopes. To ensure the safety, obtain optimum performance and to familiarize yourself fully with the use of this microscope, we recommend that you study this manual thoroughly before operating the microscope. Retain this instruction manual in an easily accessible place near the work desk for future reference.



A X 6 6 1 1

CONTENTS

IMPORTANT – Be sure to read this section for safe use of the equipment. – 1-2
--

1	MODULES AND NOMENCLATURE	3-4
2	SUMMARY OF OBSERVATION PROCEDURE	5
3	OPERATION	6-10
3-1	Base	6
1	Using the Stage Plate	6
2	Adjusting the Focus Adjustment Knob Tension	6
3-2	Microscope Body	6-10
1	Adjusting the Interpupillary Distance	6
2	Adjusting the Diopter (Zoom Confocality Adjustment)	6
3	Using the High/Low Zoom Magnification Stopper	7
4	Using the Eye Shades	8
5	Mounting the Eyepiece Micrometer Disk	8
6	Using the Auxiliary Objectives	9
7	Selecting the Light Path (SZ61TR)	9
8	Adjusting the Confocality of TV Camera (SZ61TR)	10
4	TROUBLESHOOTING GUIDE	11
5	SPECIFICATIONS	12
6	OPTICAL PERFORMANCE	13
7	ASSEMBLY	14-16
8	OPTIONAL MODULES	17-23
8-1	BX Stage Adapter Type 1 SZX-STAD1	17-18
8-2	Stage Adapter Type 1 SZH-STAD1	19
8-3	Up/Down Moving Stage SZ2-FO	19-21
8-4	Gliding Stage SZH-SG	21-22
8-5	Cup Stage SZH-SC	22-23

IMPORTANT

The SZ2 series of stereo microscopes are provided with ESD (Electro-Static Discharge) protection specifications. They are provided with electroconductive coating in their external finish to reduce the surface resistance and grounding lead wires in their standard base or frame to eliminate static electricity from them.

CAUTION To maintain the ESD protection performance, always use the microscope in combination with the modules described in this manual or options having the ESD protection specifications. Otherwise, the grounding will not work properly.

- The eye shades of the eyepieces are not provided with the ESD protection performance. Be sure to remove them.
- The SZ2-SPBW stage plate is provided with the ESD protection performance only in the black surface.

⚠ SAFETY PRECAUTIONS

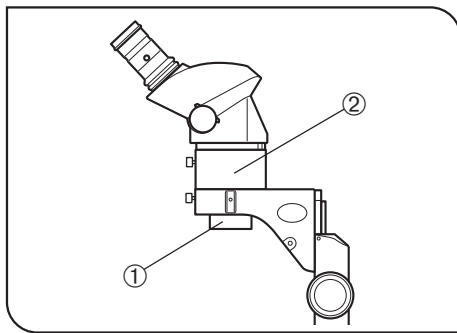
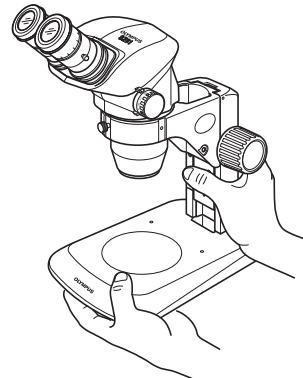

Fig. 1

1. After the equipment has been used in an observation of a specimen that is accompanied with a potential of infection, clean the parts coming in contact with the specimen to prevent infection.

- Moving this microscope is accompanied with the risk of dropping the specimen. Be sure to remove the specimen before moving this product.



- Hold the bottom of the stand with one hand while holding base column with the other hand to avoid tilting the microscope.
- In case the specimen is damaged by erroneous operation, promptly take the infection prevention measures.

2. When the optional 0.5X auxiliary objective ① is used, the microscope become unstable due to the use of the SZ2-ET auxiliary sleeve ②. Be careful not to topple down the microscope. (Fig. 1)

In addition, when a TV camera is mounted on the SZ61TR, special care is required because the microscope becomes more unstable.

1 Getting Ready

1. A microscope is a precision instrument. Handle it with care and avoid subjecting it to sudden or severe impact.
2. Do not use the microscope where it is subjected to direct sunlight, high temperature and humidity, dust or vibrations. (For the operating conditions, see "SPECIFICATIONS" on page 12.)
3. Be careful not to leave stains and fingerprints on the lens surfaces.
Contamination of the lens and mirror deteriorates the view of images.
4. Do not turn the left and right zoom adjustment knobs in the opposite directions, as this will result in a failure.
5. The rubber parts of the eyepiece sleeves are fragile and should be handled carefully. If they are damaged, dirt will penetrate inside the microscope.

2 Maintenance and Storage

- To clean the lenses and other glass components, simply blow dirty away using a commercially available blower and wipe gently using a piece of cleaning paper (or clean gauze).
If a lens is stained with fingerprints or oil smudges, wipe it gauze slightly moistened with commercially available absolute alcohol.
▲ Since the absolute alcohol is highly flammable, it must be handled carefully.
Be sure to keep it away from open flames or potential sources of electrical sparks — for example, electrical equipment that is being switched on or off.
Also remember to always use it only in a well-ventilated room.
- Do not attempt to use organic solvents to clean the microscope components other than the glass components. To clean them, use a lint-free, soft cloth slightly moistened with a diluted neutral detergent.
- Do not disassemble any part of the microscope as this could result in malfunction or reduced performance.
- When disposing of the microscope. Check the regulations and rules of your local government and be sure to observe them.

3 Caution

If the microscope is used in a manner not specified by this manual, the safety of the user may be imperiled. In addition, the equipment may also be damaged. Always use the equipment as outlined in this instruction manual.

The following symbols are used to set off text in this instruction manual.

- ▲ : Indicates that failure to follow the instructions in the warning could result in bodily harm to the user and/or damage to equipment (including objects in the vicinity of the equipment).
- ★ : Indicates that failure to follow the instructions could result in damage to equipment.
- ◎ : Indicates commentary (for ease of operation and maintenance).

4 Intended use

This product has been designed to be used to observe magnified images of specimens in various routine work and research applications.

This includes the observation of living cells or of specimen taken from tissues to gain physiological or morphological information at hospitals or laboratories.

Typical field of applications are genetics, human blood and tissue examination, neurology, pharmacology and cellular biology.

Further applications of this device include measurement and imaging for materials research, precision manufacturing, electronics design and medical device fabrication additional industrial applications are added by individual companies and researchers.

Do not use this product for any purpose other than its intended use.



This device complies with the requirements of directive 98/79/EC concerning in vitro diagnostic medical devices. CE marking means the conformity to the directive.

1 MODULES AND NOMENCLATURE

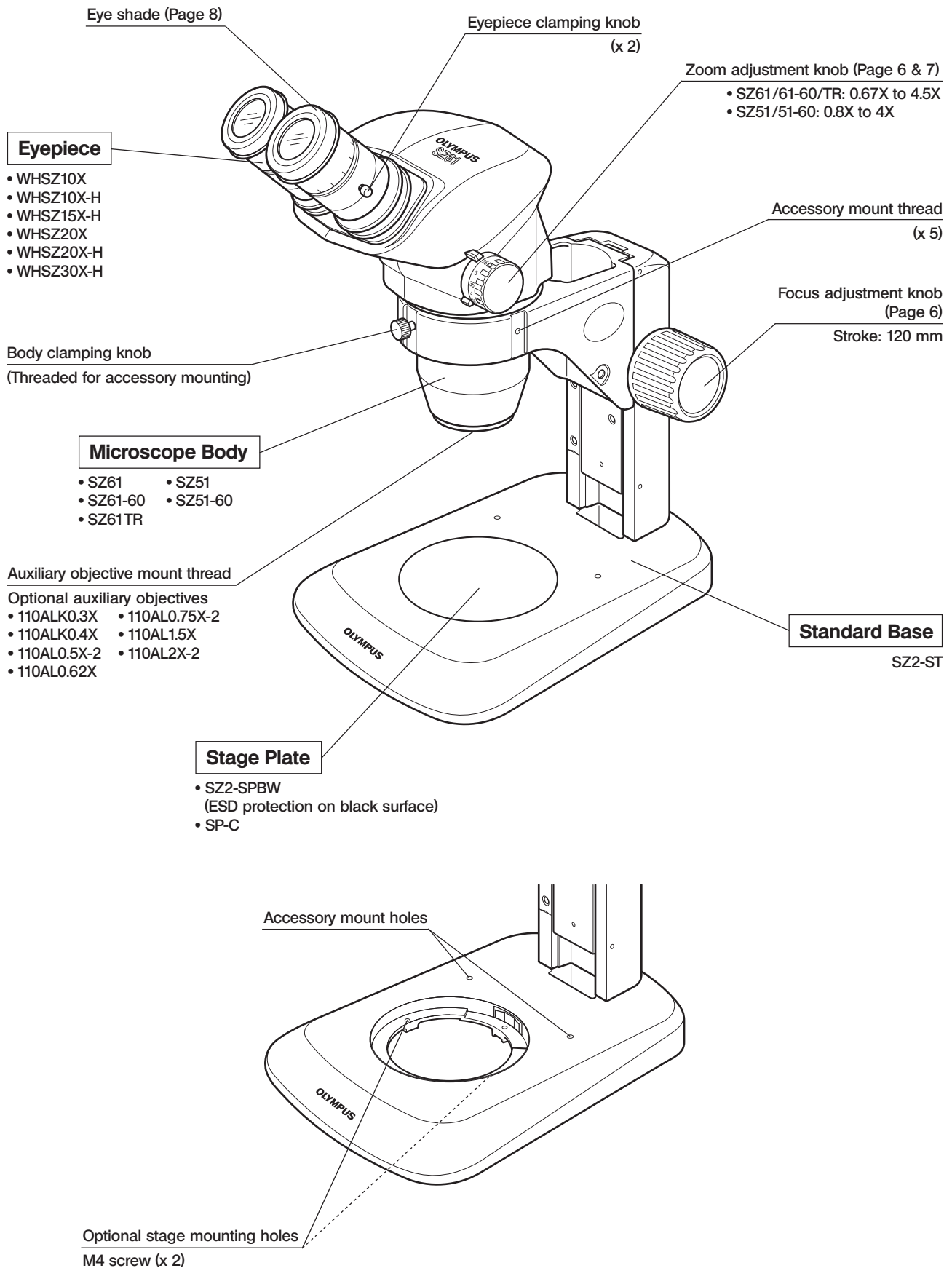

Observation Tube of SZ61TR

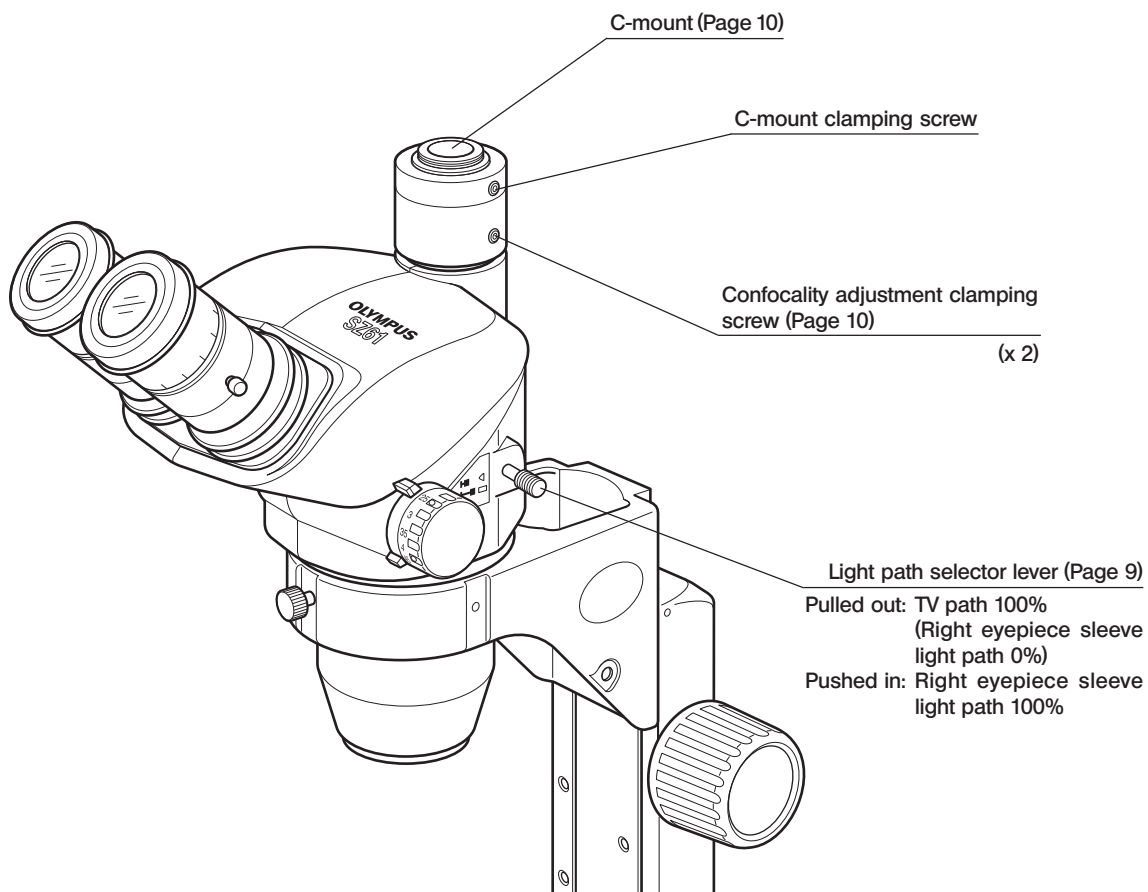

2 SUMMARY OF OBSERVATION PROCEDURE

2-1 Preparation

(Page)

1. Confirm the mounting, particularly that of the microscope body. (P. 14 - 16)
2. Confirm that the eyepieces are positioned correctly with respect to the standard base. (P. 15)
3. Adjust the rotation tension of the focus adjustment knob. (P. 6)
4. Prepare the light source as required.

2-2 Observation Procedure

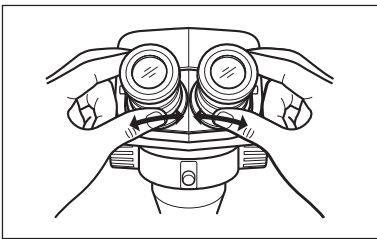

1. Place the specimen on the stage plate. (Page 6)
2. Adjust the interpupillary distance. (Page 6)
3. Adjust the eyepiece diopter. (Pages 6 & 7)
(Note) This operation is not possible with the eyepieces without helicoids (WHSZ10X/20X).

The operation is slightly different when a micrometer is mounted in one of the eyepieces with helicoids.

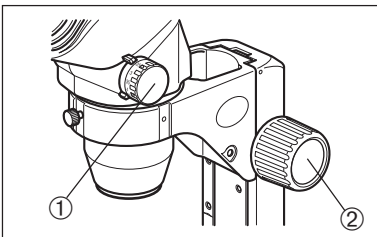
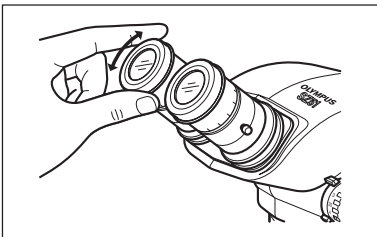

4. Set the zoom adjustment knob ① for the lowest magnification and rotate the focus adjustment knob ② to bring the specimen into approximate focus.
5. Rotate the zoom adjustment knob ① to the target magnification and rotate the focus adjustment knob ② to bring the specimen into accurate focus.

3 OPERATION

3-1 Base

1 Using the Stage Plate

When reflected light illumination is used, the stage plate can be placed either the white or black surface facing up depending on which side makes the specimen easier to view.

★ To maintain the ESD performance, use the black surface of the SZ2-SPBW stage plate.

★ When transmitted light illumination is used, use the optional SP-C transparent glass stage plate.

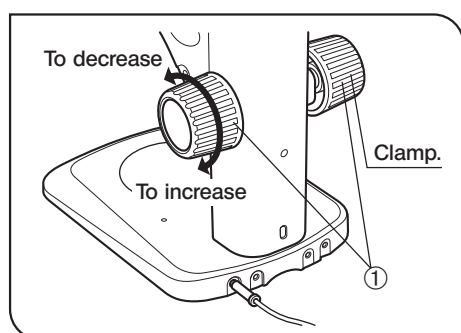

Fig. 2

2 Adjusting the Focus Adjustment Knob Tension (Fig. 2)

Ⓞ This operation is intended to facilitate the rotation of the knobs while preventing spontaneous drop of the microscope body. It is recommended to set the knob tension to a slightly higher level than the point where spontaneous drop occurs.

- Hold the left and right focus adjustment knobs ① with both hands, fix the left knob and rotate the right knob. The rotation tension of the knobs increases or decreases according to the direction in which the right knob is rotated.

3-2 Microscope Body

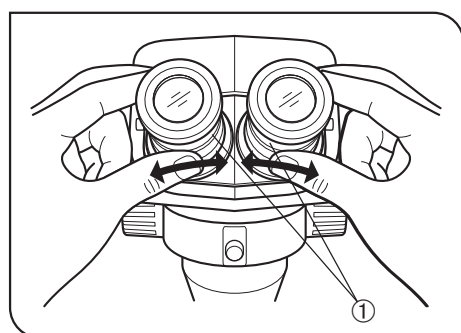

Fig. 3

1 Adjusting the Interpupillary Distance (Fig. 3)

While holding the left and right eyepiece sleeves ① with both hands, look through the eyepieces and adjust for binocular vision until the left and right fields of view coincide completely.

2 Adjusting the Diopter (Zoom Confocality Adjustment) (Figs. 4 & 5)

Ⓞ The adjustment operation is variable whether the eyepieces use an eyepiece micrometer disks or not.

Eyepieces without eyepiece micrometer disk

1. Turn the diopter adjustment rings ② of the left and right eyepieces to positions "0".
2. Place an easy-to-observe specimen on the stage plate.
3. Set the zoom adjustment knob ③ for the lowest magnification and rotate the focus adjustment knob ④ to bring the specimen into focus.
4. Set the zoom adjustment knob ③ for the highest magnification and rotate the focus adjustment knob ④ to bring the specimen into focus.
5. Set the zoom adjustment knob ③ for the lowest magnification and rotate the diopter adjustment rings ② of the left and right eyepieces, instead of the focus adjustment knob, to bring the specimen into focus.

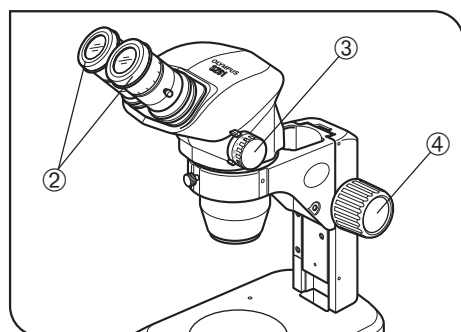

Fig. 4

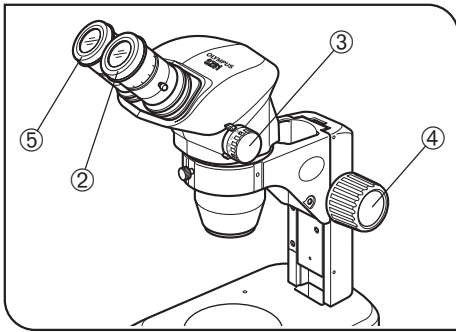

Fig. 5

Eyepieces with eyepiece micrometer disk

1. Look through the eyepiece with eyepiece micrometer disk and rotate its diopter adjustment rings ② to bring the micrometer scale into focus.
2. Place an easy-to-observe specimen on the stage plate.
3. Set the zoom adjustment knob ③ for low magnification, look through the eyepiece with eyepiece micrometer disk and rotate the focus adjustment knob ④ to bring the specimen into focus.
4. Set the zoom adjustment knob ③ for the highest magnification and rotate the focus adjustment knob ④ to bring the specimen into focus.
5. Set the zoom adjustment knob ③ for the lowest magnification and rotate the diopter adjustment ring ⑤ of the eyepiece without eyepiece micrometer disk, instead of the focus adjustment knob ④, to bring the specimen into focus.

⊙ Note the left and right diopter scale values so that it can be quickly duplicated in future observations.

Diopter scale of the 10X eyepieces

⊙ The valid range of the diopter scale is between -8 and $+5$ but a slight margin is added to it. Therefore, the diopter value may exceed $+5$ or -8 when it is adjusted to the maximum. In this case, whether the diopter value is over $+8$ or under -5 can be identified by the length of the eyepiece.

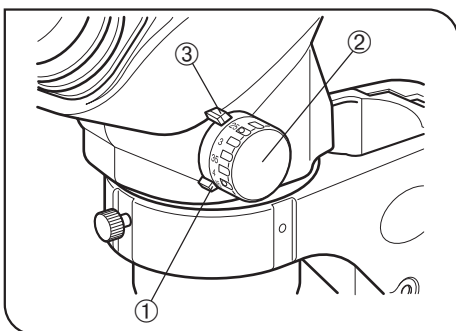
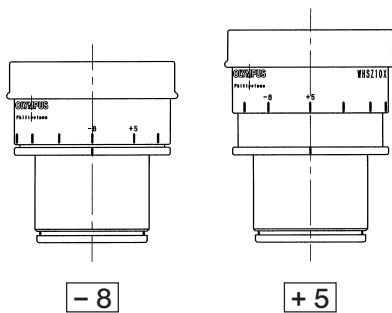

Fig. 6

3 Using the High/Low Zoom Magnification Stopper

(Fig. 6)

⊙ The magnification can be limited in the desired range by setting each stopper on the microscope body (also used as the magnification indices) and the stopper ring on each zoom adjustment knob. The right zoom adjustment knob is used to limit the higher end of the magnification, and the left knob is used to limit the lower end.

1. Using an Allen wrench, loosen the clamping screw of the right stopper ring ① and free it. (Also free the left knob in this way)
2. Rotate the right zoom adjustment knob ② to align the desired higher-limit magnification with the index (stopper) ③.
3. Gently apply the stopper ring ① to the stopper ③ and tighten the clamping screw using the Allen wrench to retain this condition.
4. Set the left zoom adjustment knob according to the desired lower-limit magnification by rotating the left knob and clamping the left stopper ring in the same way as above.

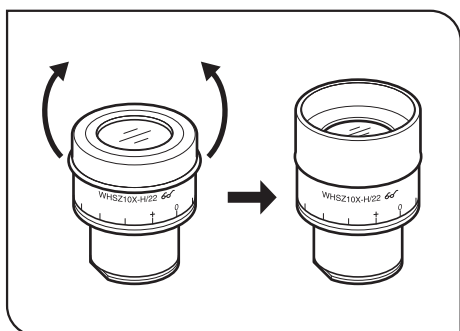

Fig. 7

4 Using the Eye Shades

(Fig. 7)

★ The eye shades are not provided with ESD protection performance. When ESD protection is required, do not use the eye shades.

When Wearing Eyeglasses

Use with the eye shades in the normal, folded-down position. This will prevent the eyeglasses from being scratched.

When Not Wearing Eyeglasses

Extend the folded eye shades in the direction of the arrow to prevent extraneous light from entering between the eyepieces and eyes.

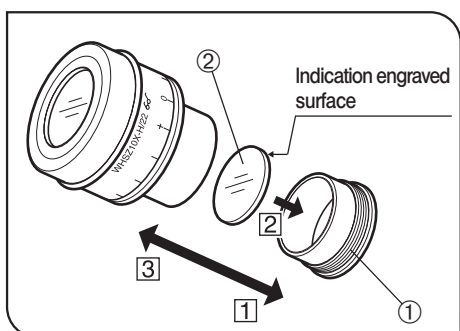

Fig. 8

5 Mounting the Eyepiece Micrometer Disk (Figs. 8 & 9)

WHSZ10X-H/15X-H/20X-H (Fig. 8)

1. Rotate the disk-mounting ring ① of the eyepiece counterclockwise to remove.
2. Prepare an eyepiece micrometer disk ② (24 mm dia. x 1.5 mm thick), remove dust and dirt from its surface, and fit it into the disk-mounting ring ① so that the engraving on the micrometer disk faces downward.
3. Gently screw in the disk-mounting ring ① incorporating the eyepiece micrometer disk into the eyepiece. Turn the ring clockwise to attach it firmly.

WHSZ30X-H (Fig. 9)

1. Rotate the disk-mounting ring ③ of the eyepiece counterclockwise to remove.
2. Rotate the push ring ④ of the eyepiece micrometer disk counterclockwise to remove.
3. Prepare an eyepiece micrometer disk ⑤ (24 mm dia. x 1.5 mm thick), remove dust and dirt from its surface, place it on the disk-mounting ring ③ with the engraving facing downward, and fix it with the push ring ④.
4. Gently screw in the disk-mounting ring ③ incorporating the eyepiece micrometer disk into the eyepiece. Turn the ring clockwise to attach it firmly.

Ⓞ The micrometer disk frame may be tight for certain micrometer disks. In this case, turn the frame by holding the circumference with a light, uniform force or by applying the frame against a rubber sheet. Do not grasp the frame with a strong force, as this may deform the frame and make it harder to remove it.

Ⓞ Be careful not to touch the lens surface with your finger.

★ Due to their structures the WHSZ20X-H/30X-H eyepieces apply a magnification on the focused plane of the eyepiece micrometer disk. These magnifications are 1.3X with the WHSZ20X-H and 2X with the WHSZ30X-H. Be sure to compensate for these magnifications when using the eyepiece micrometer disk in measurements.

Also, insertion of the eyepiece micrometer disk extends the light path length and deviates the position of the diopter scale. Correct this deviation by turning the diopter adjustment ring of the eyepiece toward “+”.

Ⓞ When the eyepiece micrometer disk is not used, store it by wrapping in a clean, soft cloth.

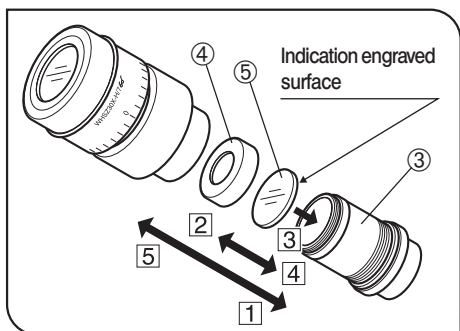

Fig. 9

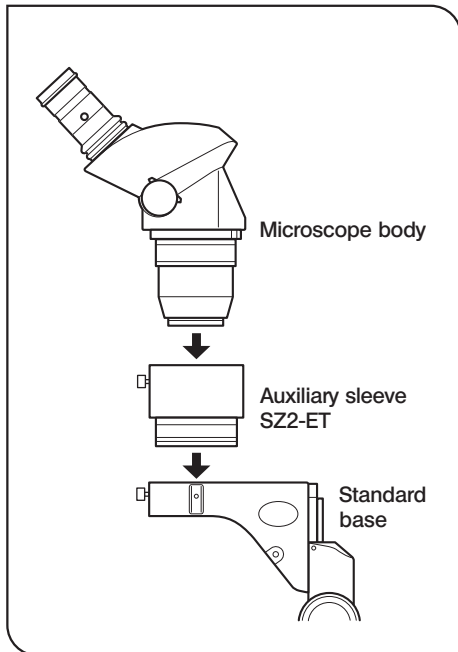

Fig. 10

6 Using the Auxiliary Objectives

(Fig. 10)

- ◎ All of the auxiliary objectives are provided with the ESD protection performance.
- ★ The 0.3X and 0.4X auxiliary objectives cannot be used in combination with the standard base because their working distances are too long.
- ★ The 0.5X auxiliary objective (110AL0.5X-2) also has a long working distance, but this can be combined with the standard base provided that the auxiliary sleeve (SZ2-ET) is used. In this case, however, the microscope becomes unstable and needs care against toppling it down.
- Screw the auxiliary objective firmly into the auxiliary objective mount thread at the bottom of the microscope body.

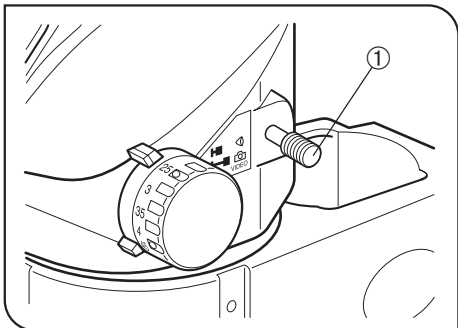

Fig. 11

7 Selecting the Light Path (SZ61TR)

(Fig. 11)

- ★ Always move the light path selector lever ① until it hits the stop position.
1. For observation through the binocular light path, push in the light path selector lever ① till the stop position. (Fig. 11)
In this position, the whole light (100%) goes to the binocular tube.
 2. For the TV camera light path, pull out the light path selector lever ① till the stop position. (Fig. 11)
In this position, a mirror is inserted into the light path so the whole light for the right eyepiece sleeve (100%) is sent to the TV light path.

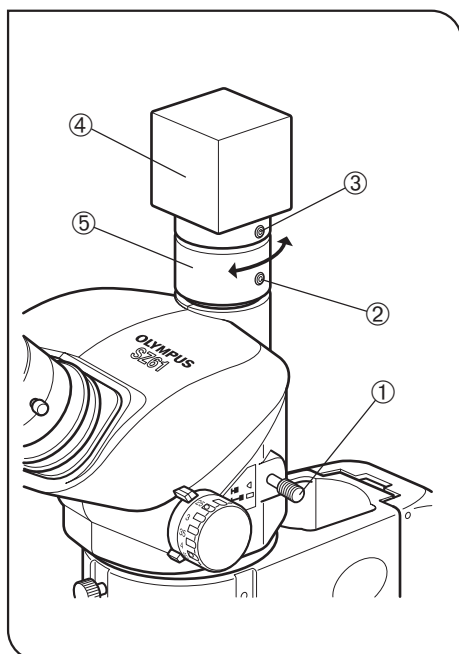

Fig. 12

8 Adjusting the Confocality of TV Camera (SZ61TR)

(Fig. 12)

Ⓞ Ensuring the confocality between the observation image and the TV camera monitor image makes it possible to maintain accurate focusing of the observation image or monitor image even when the light path is switched.

1. Adjust the diopter of the eyepiece (see pages 6 and 7) and bring the specimen into focus.
 2. Pull out the light path selector lever ① and set the magnification to the minimum.
 3. Slightly loosen the two confocality adjustment clamping screws ② and C-mount clamping screw ③.
 4. Hold the TV camera ④ and rotate the confocality ⑤ to focus on the monitor image.
- After the adjustment, tighten the clamping screws ② and ③.

Applicable cameras (image pickup device size) and field numbers

Ⓞ The TV camera light path incorporates a 0.5X lens.

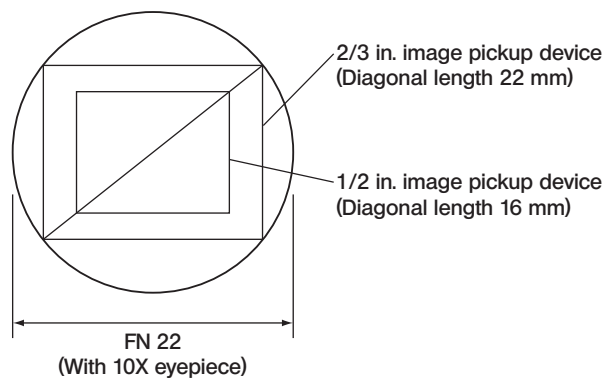

Rotation of monitor image

The monitor image is rotated slightly because the right observation light path, which is tilted slightly, is used as the TV light path.

The monitor image can be aligned with the observation image by rotating the TV camera.

4 TROUBLESHOOTING GUIDE

Under certain conditions, performance of the microscope may be adversely affected by factors other than defects. If problems occur, please review the following list and take remedial action as needed. If you cannot solve the problem after checking the entire list, please contact Olympus.

Problem	Cause	Remedy	Page
1. The left and right fields of view do not coincide.	Interpupillary distance is adjusted improperly.	Adjust it correctly.	6
	The parallax is not corrected.	Adjust it correctly.	6-7
	The magnifications of the left and right eyepieces are different.	Use the eyepieces with the same magnification for the left and right by replacing one of them.	3
2. Dirt or dust is visible in the field of view.	Dirt/dust on specimen.	Clean thoroughly.	2
	Dirt/dust on eyepieces		
3. Visibility of observed image is poor.	Dirt/dust on the dustproof glass on the tip of the objective.	Clean thoroughly.	2
4. Zooming causes defocusing of the observed image.	The eyepiece diopter is adjusted improperly.	Adjust it correctly.	6-7
	The focus adjustment is inaccurate.	Adjust the focus accurately.	5
5. The focus adjustment knob does not rotate smoothly.	The rotation tension of the knob is set too high.	Decrease the rotation tension to an optimum level.	6
6. The microscope body drops spontaneously, causing the focusing to be deviated during observation.	The rotation tension of the knob is set too low.	Increase the rotation tension to an optimum level.	6
7. The right field of view or the monitor image is cut off.	The light path selector lever is not set properly to a stop position.	Push in or pull out the lever all the way till the stop position.	9
8. Zooming causes important defocusing of the monitor image.	The confocality of the TV camera is adjusted improperly.	Adjust it properly.	10

5 SPECIFICATIONS

Item		SZ61	SZ61-60	SZ61TR	SZ51	SZ51-60
Microscope body	Magnification	0.67X to 4.5X			0.8X to 4X	
	Zoom ratio	6.7			5	
	Working distance	110 mm				
	Tube tilting angle	45°	60°	45°		60°
	Interpupillary distance adjustment	Left/right interlocked. Adjustment range: 52 to 76 mm (using the WHSZ10X eyepieces)				
	TV camera compatibility	—		C-mount (0.5X lens built in)	—	
	Zoom adjustment knobs	Left/right single-shaft horizontal knobs (with high/low zoom magnification stopper)				
	Auxiliary objective	Mounting by screwing into the thread at the bottom of frame (M48 thread x 0.75)				
Eyepieces**		WHSZ10X-H: FN 22, 24 mm eyepiece micrometer disk mountable				
		WHSZ15X-H: FN 16, 24 mm eyepiece micrometer disk mountable*				
		WHSZ20X-H: FN 12.5, 24 mm eyepiece micrometer disk mountable*				
		WHSZ30X-H: FN 7, 24 mm eyepiece micrometer disk mountable*				
Base	Frame installation	Mounting diameter 76 mm				
	Focus adjustment	Rack-and-pinion using ball guide Knob rotation tension adjustable Focusing stroke 120 mm				
	Stage plate	Diameter 100 mm, milky white (back side black)				
	Light source installation	Oblique illumination system (LSGA), light guide illumination system (SZ2-LGB) or transmitted light illumination base mountable.				
Operating environment		<ul style="list-style-type: none"> • Indoor use • Altitude: Max. 2000 m • Ambient temperature: 5° to 40°C (41° to 104°F) • Maximum relative humidity: 80% for temperatures up to 31°C (88°F), decreasing linearly through 70% at 34°C (93°F), 60% at 37°C (99°F), to 50% relative humidity at 40°C (104°F) • Supply voltage fluctuations: ±10% • Pollution degree: 2 (in accordance with IEC60664) • Installation (overvoltage) category: II (in accordance with IEC60664) 				

* The micrometer and squared scale outside the field number are invisible.

** The WHSZ10X and WHSZ20X eyepieces without helicoids are also available. (An eyepiece micrometer cannot be mounted)

6 OPTICAL PERFORMANCE

★ The following data shows only the typical magnifications of each zoom magnification.

Zoom Magnification	Working Distance (mm)	Eyepieces							
		WHSZ10X FN 22		WHSZ15X FN 16		WHSZ20X FN 12.5		WHSZ30X FN 7	
		Total Power	Actual Field (mm)	Total Power	Actual Field (mm)	Total Power	Actual Field (mm)	Total Power	Actual Field (mm)
0.67X	110	6.7X	32.8	10X	23.8	13.4X	18.7	20X	10.4
0.8X		8X	27.5	12X	20	16X	15.6	24X	8.8
1X		10X	22	15X	16	20X	12.5	30X	7
2X		20X	11	30X	8	40X	6.3	60X	3.5
4X		40X	5.5	60X	4	60X	3.1	120X	1.8
4.5X		45X	4.89	67.5X	3.6	90X	2.8	135X	1.6

■ Auxiliary objectives (optional)

Auxiliary Objective		Working Distance (mm)	Auxiliary Objective		Working Distance (mm)
110ALK	0.3X	350 - 250	110AL	0.75X-2	130
110ALK	0.4X	250 - 180	110AL	1.5X	61
110AL	0.5X-2	200	110AL	2X-2	38
110AL	0.62X	160			

★ The working distances of the 110ALK0.3X and 0.4X can be varied according to the system.

The indicated magnifications (0.3X and 0.4X) are the values when the working distances are 350 mm and 240 mm respectively.

★ The 110AL2X-2 cannot be combined with the optional SZ2-LGR ring light guide illumination system.

◎ The working distance is constant regardless of the zoom magnification.

◎ The total power and actual field can be calculated with the following formulae.

Total power = Zoom magnification x Eyepiece magnification x Auxiliary objective magnification*

$$\text{Actual field} = \frac{\text{Eyepiece FN}}{\text{Zoom magnification} \times \text{Auxiliary objective magnification}^*}$$

*This value is 1X when the auxiliary objective is not used.

7 ASSEMBLY

7-1 Assembly Diagram

The diagram below shows the sequence of assembly of the various modules. The numbers indicate the order of assembly.

Assembly steps enclosed in **■** will be detailed on the subsequent pages.

★ When assembling the microscope, make sure that all parts are free of dust and dirt, and avoid scratching any parts or touching glass surfaces.

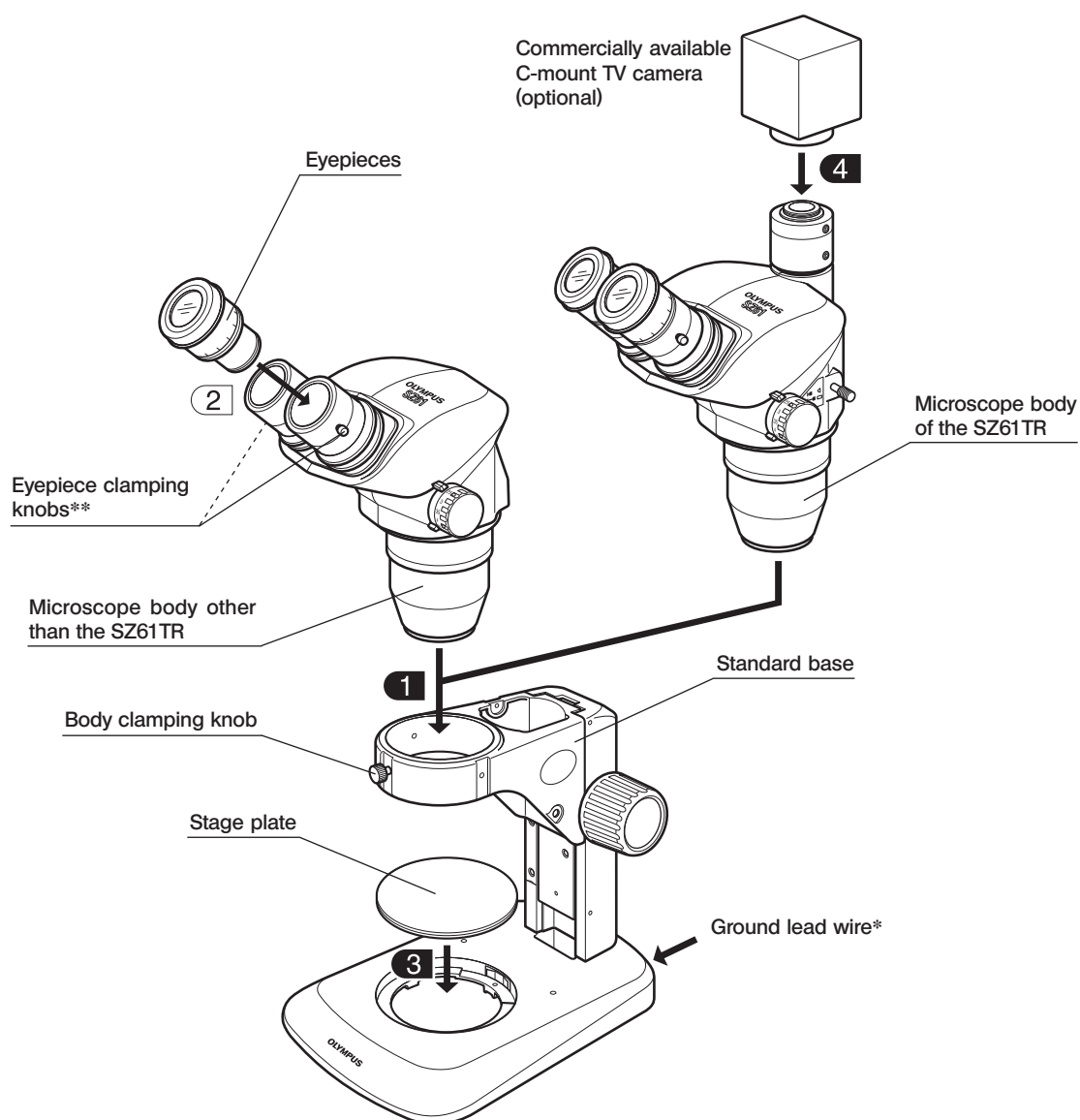

* To reserve the ESD protection performance, be sure to ground the equipment using a grounding lead wire having a 4 mm banana plug.

** The eyepieces are provided with theft prevention screws (which can be retained using a flat-blade screw driver). If required, replace the clamping knobs with these screws.

7-2 Detailed Assembly Procedures

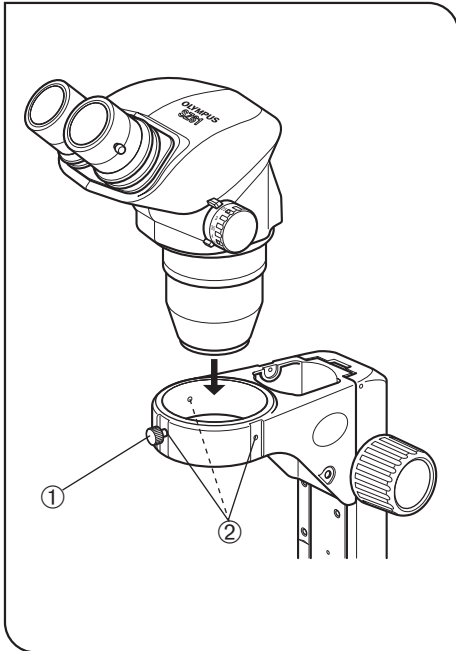

Fig. 13

1 Installing the Microscope Body (Fig. 13)

(Fig. 13)

- Loosen the body clamping knob ① and insert the microscope body gently.
- Ⓞ The body clamping knob ① can be attached to any of the three positions ② around the arm. After installation, attach the knob to a position so that the knob does not come in the way of the light source, etc.
- Ⓞ If you always perform observation from the side of the focus adjustment knobs, the microscope body can be installed in the opposite orientation to that shown in Fig. 13 (at the 180° rotated position).

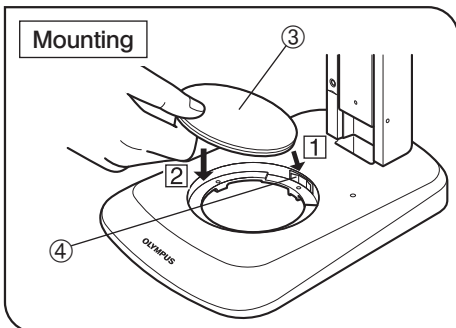

Fig. 14

3 Mounting the Stage Plate (Figs. 14 & 15)

(Figs. 14 & 15)

1. While applying the stage plate ③ to the stage plate holder spring ④, fit the stage plate into the hole and push it from upward to secure the mounting.
 - Ⓞ The stage plate ③ has the milky white and black surfaces. Select the side facing up according to the specimen.
2. To dismantle the stage plate ③, push the stage plate edge near the holder spring ④. As this moves up the opposite edge of the stage plate, dismantle it by holding that edge.

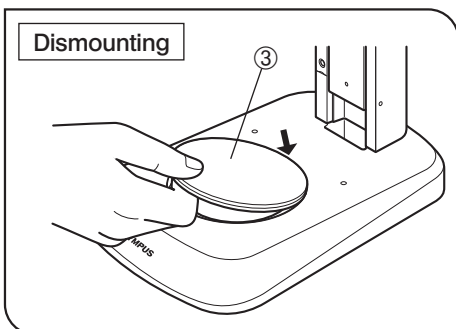

Fig. 15

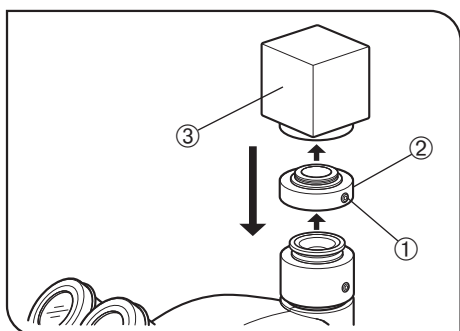

Fig. 16

4 Mounting the TV Camera (SZ61TR only) (Fig. 16)

1. Using the Allen wrench, loosen the C-mount clamping screw ① and remove the C-mount seat ②.
2. Screw the C-mount seat ② into the TV camera ③.
3. Place the C-mount seat in the original position and tighten the clamping screw ①.
4. Connect the cables and monitor to the TV camera.

8 OPTIONAL MODULES

8-1 BX Stage Adapter Type 1 SZX-STAD1

1 Introduction

The SZX-STAD1 is an adapter for use in mounting the U-SRG or U-SRP rotary stage on the SZ2-ST standard base, SZ-ST standard base, large base or SZX illumination base. The U-SRP is used in combination with the U-FMP mechanical stage to enable movement in the X- and Y-directions, which is convenient for framing in photomicrography or TV observation. To compensate for the height of the stage adapter, it is recommended to use also the SZ2-ET auxiliary sleeve when the SZ2-ST is used or the SZH-P400 auxiliary column (and the SZX-R drop prevention ring also) when the SZX-ST or SZX illumination base is used.

2 Applicable Bases and Restrictions

Base	Applicable Auxiliary Objectives	Restrictions
<ul style="list-style-type: none">• Standard base SZ2-ST SZX-ST• Large base SZ-STL SZX-STL	0.5X to 2X	None
<ul style="list-style-type: none">• Transmitted illumination base SZX-ILLK SZX-ILLB2 SZX-ILLD2	The restrictions are identical whether or not the stage adapter is used. (Refer to the instruction manual for the SZX illumination base.) The transmitted light illumination field may be limited depending on the diameter of the hole on the stage center plate in use. ★ Darkfield observation is not available with the SZX-ILLD2. ★ The brightness drops when a frost filter is used.	

3 Installation

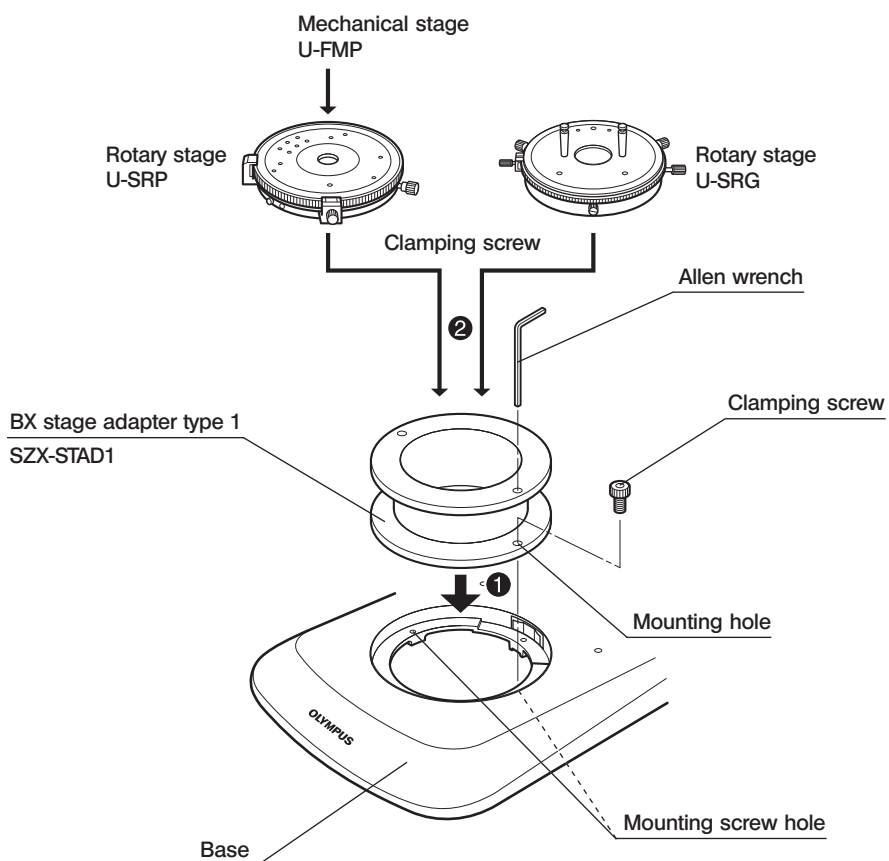

Mounting the polarizer (SZX-PO or SZ-POL-2)

When simplified transmitted light polarized observation is required, mount the polarizer on the BX stage adapter type 1 (SZX-STAD1).

Drop the polarizer frame into the polarizer mount seat at the top of the SZX-STAD1.

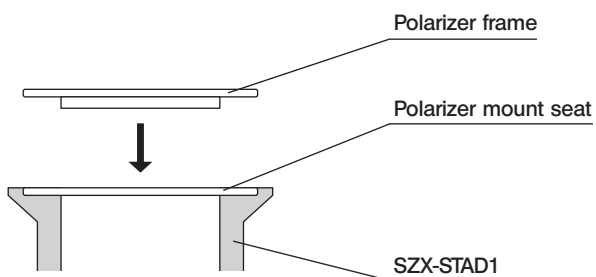

8-2 Stage Adapter Type 1 SZH-STAD1

The SZH-STAD1 is an adapter providing the similar function to the BX stage adapter type 1 (SZX-STAD1). The applicable stage is the BH2-SH horizontal knob stage.

The installation and polarizer (SZX-PO or SZ-POL-2) mounting methods are identical to those for the SZX-STAD1. Please read the previous section (page 18).

8-3 Up/Down Moving Stage SZ2-FO

1 Associated Module System Chart

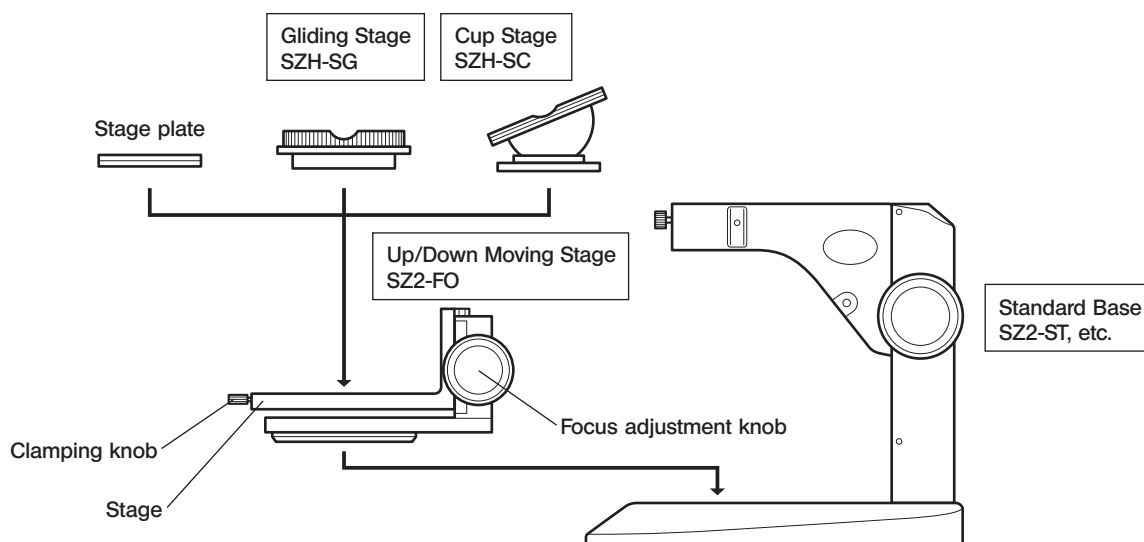

★ When using a filter or simplified polarized light system in combination with the transmitted illumination base, mount the filter holder or polarizer on the base before installing the up/down moving stage.

★ The up/down moving stage can also be mounted so that the focus adjustment knob comes on the side of the observer (180° opposite to the orientation shown in the above figure).

Modules Mountable on the SZ2-FO

- Stage plate : SZ2-SPBW, SP-C
- Base : SZ2-ST, SZX-ST, SZ-STL, SZX-STL, SZX illumination base series
- Stage : SZX-SC, SZH-SG*
 - * The front/rear movement is possible only on the front side of the center because the focus adjustment knobs of the SZ2-FO comes in the way.
- Auxiliary objectives : Objectives with 0.5X or less cannot be used due to insufficiency in the focusing stroke. The 0.5X objective can be used by adding a 400 mm column to the SZX-ST.

2 External View and Nomenclature

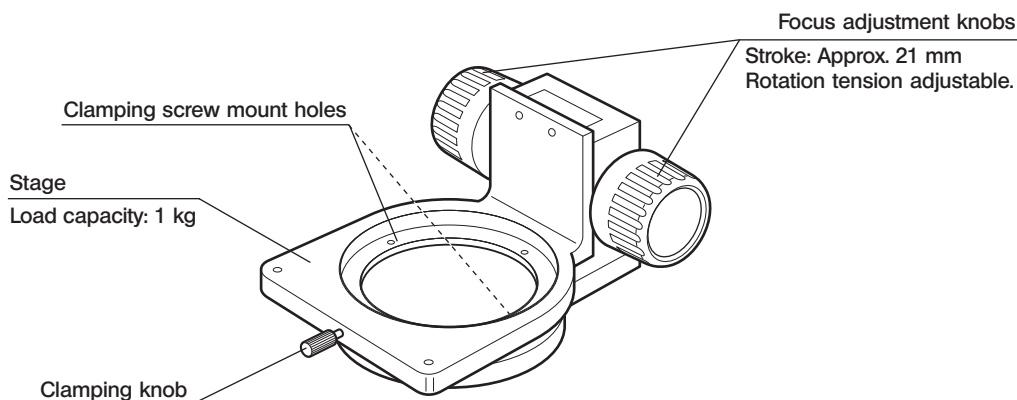

3 Installation

- Using the provided screw and Allen wrench, attach the SZ2-FO up/down moving stage into the screw hole on the stage plate mount hole of an applicable base or that on the stage plate (SZ-STL).
The SZ2-FO can also be installed so that the focus adjustment knobs are located on the near side of the operator. This orientation is obligatory when the IHE holder for the LSGA oblique illumination system is used.
- Loosen the clamping knob on the stage, attach the stage plate, SZH-SG or SZH-SC, and tighten the clamping knob again.

4 Operation

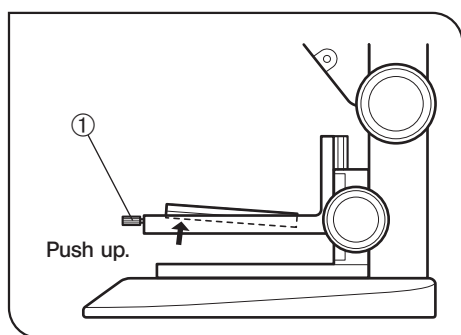

Fig. 17

Removing the stage plate (Fig. 17)

To remove the stage plate, loosen the clamping knob ① and push up the stage plate from below it.

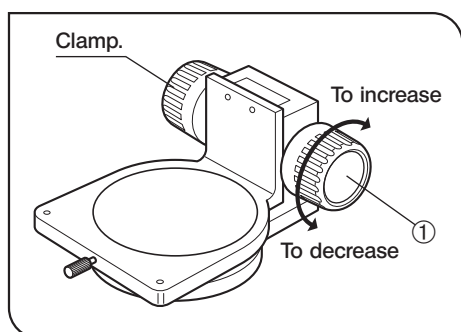

Fig. 18

Adjusting the focus adjustment knob tension (Fig. 18)

- Ⓞ This operation is intended to facilitate the rotation of the knobs while preventing spontaneous drop of the up/down moving stage. It is recommended to set the knob tension to a slightly higher level than the point where spontaneous drop occurs.
- Hold the left and right focus adjustment knobs ① with both hands, fix the left knob and rotate the right knob. The rotation tension of the knobs increases or decreases according to the direction in which the right knob is rotated.
 - If the rotation tension is increased too much, accurate focusing is not possible and the mechanism may be damaged.

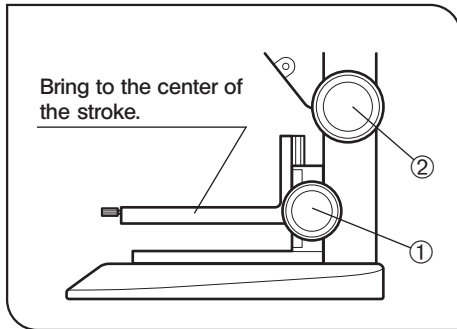

Fig. 19

Adjusting the focus (Fig. 19)

1. Rotate the focus adjustment knob ① of the SZ2-FO up/down moving stage to bring the stage at the center of the focusing stroke.
2. Place a specimen on the stage and rotate the focus adjustment knob ② of the base to bring the specimen into approximate focus. And then adjust the accurate focus using the focus adjustment knob ① of the up/down moving stage.

5 Applicable Bases and Restrictions

Base	Applicable Auxiliary Objectives	Restrictions
<ul style="list-style-type: none"> • Standard base SZ2-ST SZX-ST • Large base SZ-STL SZX-STL 	0.5X to 1.5X	None
	2X	With the SZ2-ST, install the SZ2-FO so that the focus adjustment knobs come on the side of the operator.
<ul style="list-style-type: none"> • Transmitted illumination base SZX-ILLK SZX-ILLB2 SZX-ILLD2 	<p>The restrictions are identical whether or not the stage adapter is used. (Refer to the instruction manual for the SZX illumination base.) The transmitted light illumination field may be limited depending on the diameter of the hole on the stage center plate in use.</p> <p>★ Darkfield observation is not available with the SZX-ILLD2. ★ The brightness drops when a frost filter is used.</p>	

8-4 Gliding Stage SZH-SG

1 External View and Nomenclature

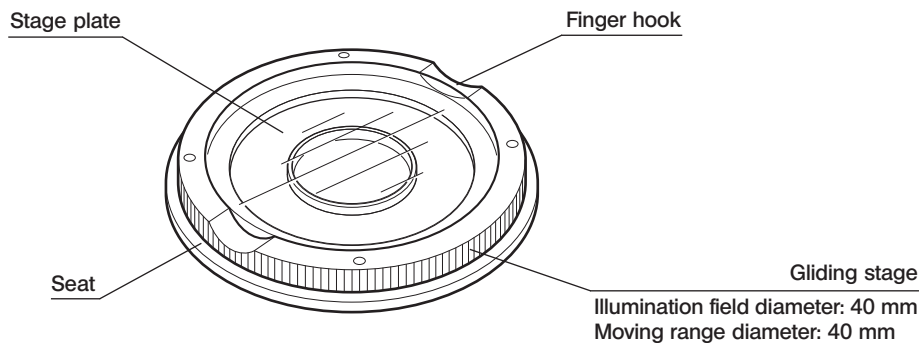

2 Installation

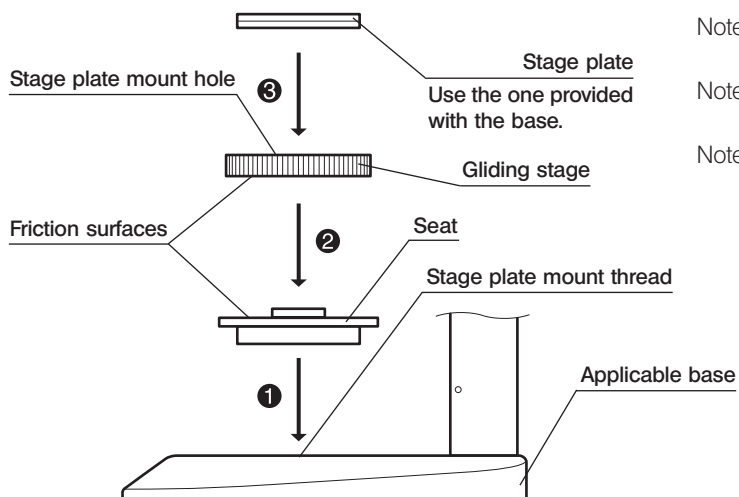

Note 1. Be sure to clean the friction surfaces if dirt or metallic power is attached on them.

Note 2. Do not place the gliding stage on the friction surface directly on the desktop.

Note 3. Clean the friction surfaces periodically.

3 Operation

Hold the gliding stage by the edge and move it horizontally.

8-5 Cup Stage SZH-SC

1 External View and Nomenclature

★ The SZH-SC can be used only with reflected light illumination.

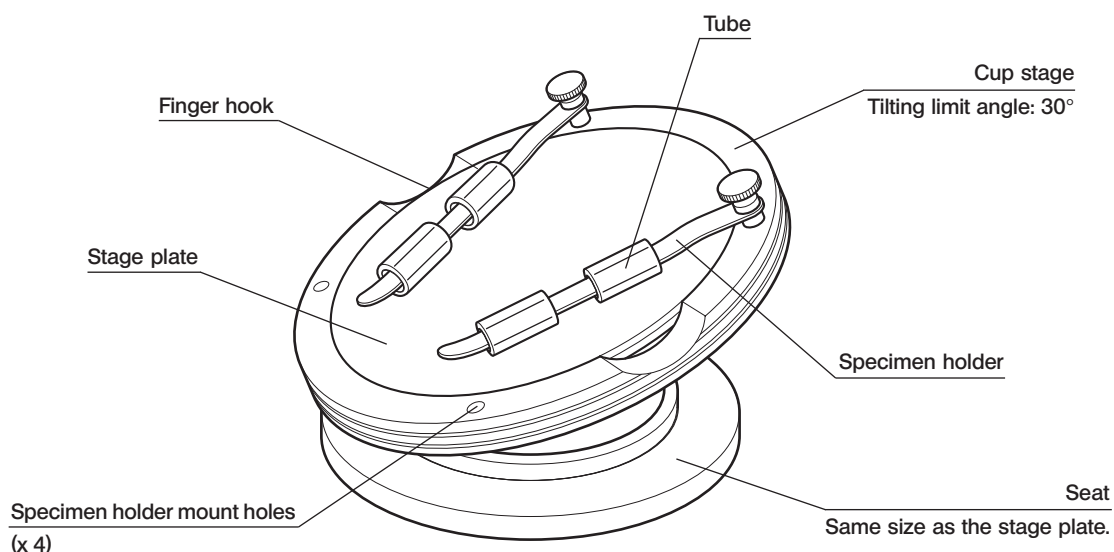

2 Installation

★ Before mounting, remove dirt and dust from the mount surfaces and handle carefully so as not to damage them.

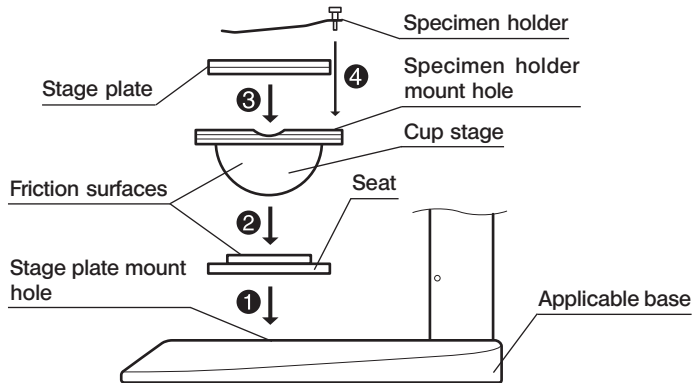

- ① Fit the cup stage seat into the stage plate mount hole of an applicable base.
 - ② Place the cup stage on the seat.
Before placing, wipe the friction surfaces on the cup stage and seat with a clean cloth.
 - ③ Mount the stage plate.
 - ④ Mount the specimen holder.
- Ⓞ Clean the friction surfaces periodically.

3 Operation

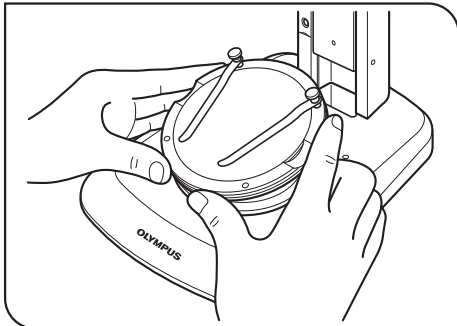

Fig. 20

Place a specimen on the stage plate, hold the cup stage by the edge, and tilt the cup stage slowly. (Fig. 20)

Ⓞ If the specimen slips on the stage plate, hold the specimen with the provided specimen holder.

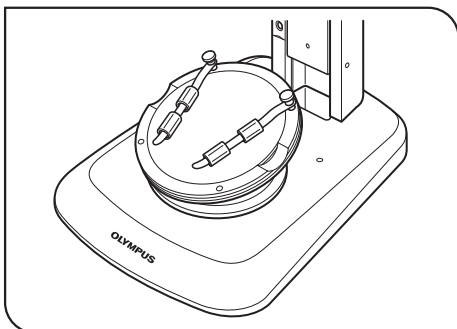

Fig. 21

Ⓞ To fix a container such as a petri dish, insert the provided tube into the specimen holder to fix the container by pinching. (Fig. 21)

CAUTION

- ★ Do not touch the friction surfaces on the cup stage and seat with a hand. If the friction surfaces are contaminated, wash with a neutral detergent before use.
- ★ If a load of more than 20 grams is applied to the edge of the cup stage, it may move spontaneously.
- ★ When a tall specimen is placed and the cup stage is tilted, the specimen may go out of focus. In this case, adjust the focus again.

OLYMPUS®

www.olympus.com



Manufactured by

OLYMPUS CORPORATION

Shinjuku Monolith, 2-3-1 Nishi-Shinjuku, Shinjuku-ku, Tokyo 163-0914, Japan

Distributed by



OLYMPUS EUROPA SE & CO. KG

Wendenstrasse 14-18, 20097 Hamburg, Germany

OLYMPUS SCIENTIFIC SOLUTIONS AMERICAS CORP.

48 Woerd Avenue Waltham, MA 02453, U.S.A.

OLYMPUS SINGAPORE PTE LTD.

491B River Valley Road, #12-01/04 Valley Point Office Tower, Singapore 248373

OLYMPUS AUSTRALIA PTY. LTD.

3 Acacia Place, Notting Hill VIC 3168, Australia

OLYMPUS LATIN AMERICA, INC.

5301 Blue Lagoon Drive, Suite 290 Miami, FL 33126, U.S.A.

OLYMPUS KOREA CO., LTD.

8F Olympus Tower, 446 Bongeunsa-ro, Gangnam-gu, Seoul, Korea 135-509

