



DeakinWeek  
2007

[www.deakin.edu.au](http://www.deakin.edu.au)

# Carbon composites: the way to reduce carbon emissions?

Dr Bronwyn Fox

1977\*2007  
DEAKIN 30 YEARS



DEAKIN

# DeakinWeek



## Outline

- > Aircraft fuel consumption and emissions
- > Aerospace composites
- > Quickstep Technology
- > Composites Research at Deakin



# DeakinWeek



<http://www.chooseclimate.org/flying/mf.html>



**Your journey needed 1189 kg fuel.** This amount:

- \*is about 17.5 times an average person's weight
- \*has a volume of 1573 litres
- \*makes 15712 kW-hrs energy when burnt, as much as the electricity used by 30 60W lightbulbs lit continuously for one year, or the food eaten by 15 people in one year.

**\*3757 kgs of CO<sub>2</sub> into atmosphere**



# DeakinWeek



- > It is common convention to describe Newton's 2<sup>nd</sup> Law

$$\text{Force} = \text{Mass} \times \text{Acceleration}$$

- > Thus if we reduce the mass of a moving object, we reduce the energy required to move it.
- > The passenger to weight ratio of a vehicle or aircraft is a key measure of its energy consumption efficiency.

**Paradox – rising fuel costs and increasing vehicle/airframe weights**

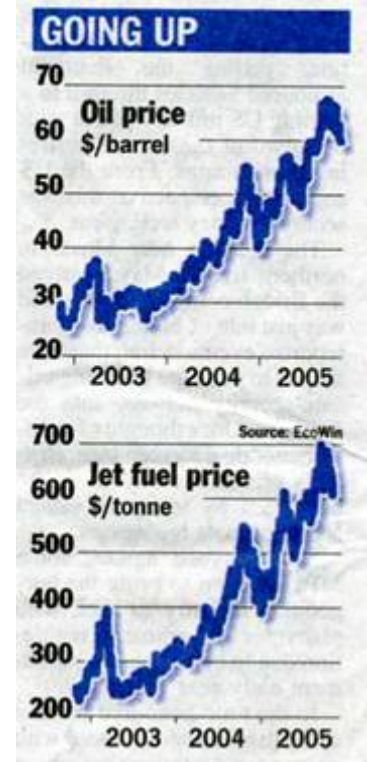

# ***Weight per passenger***

***AIRBUS A380***

***2006, 1,100kg/passenger***

***(Approx. 500,000 litres of fuel per day)***



***BOEING 707***

***1954, 700kg/passenger***

# DeakinWeek



## Less Fuel = Less Emissions

Aircraft engine emissions are directly related to fuel burn.

Each kilogram of fuel saved reduces carbon dioxide (CO<sub>2</sub>) emissions by 3.16 kg.

The key for airlines to minimise their environmental impact is to use fuel more efficiently. IATA (International Air Transport Association) airlines improved their fuel efficiency by 5% in 2004-2005 alone ([www.iata.org](http://www.iata.org)).

## Virgin Atlantic move to save fuel

By towing its Boeing 747-400 aircraft to take-off areas at London airports during December it said it could save up to two tonnes of fuel per flight.

Air traffic management (Cathay 12% waste).





## Fuel Burn

*“Triple the number of passengers flying by 2020”*

Need to reduce emissions by 65% or better?

IATA - Airlines are aiming for a further 25% fuel efficiency improvement by 2020.

How?

More efficient engines, lighter airframes.

# DeakinWeek



Airbus A380

vs

Boeing 787



# Airbus A380 vs Boeing 787

- > Hub to hub
- > 750 tons, 800 passengers
- > Wingspan 79m
- > Requires runways, boarding gates to be redesigned.



- > Point to point
- > Pressurized for lower altitude and higher humidity.
- > Mach 0.85 cruise
- > 280 passengers
- > 16,000 km range
- > Qantas has ordered 115, 65 will arrive in 2008.



# ***Airbus A380 – 590T/550 Passengers***



**PARADOX:**

**Rising Fuel Costs and Increasing  
Airframe Weight**



***A380 Fuselage***



***Carbon composite pressure bulkhead***

# ***Boeing 787 Dreamliner***



**More than 50% composite aircraft**

**Entry into service 2008 – more than 400 orders**

# 787

DREAMLINER

## One Piece Barrel



Boeing is a trademark of Boeing Management Company.  
Copyright © 2005 Boeing. All rights reserved.



***Pressurised to 6,000ft (10,000ft for aluminium aircraft)***

***Increased humidity (reduced dryness)***

***Larger passenger windows***

# DeakinWeek



## Advanced Composites

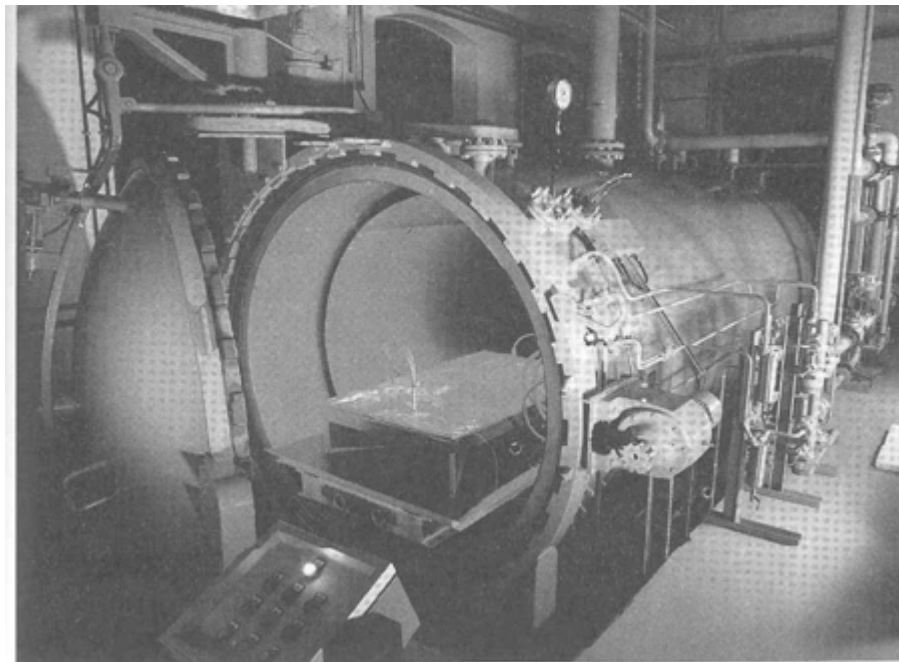
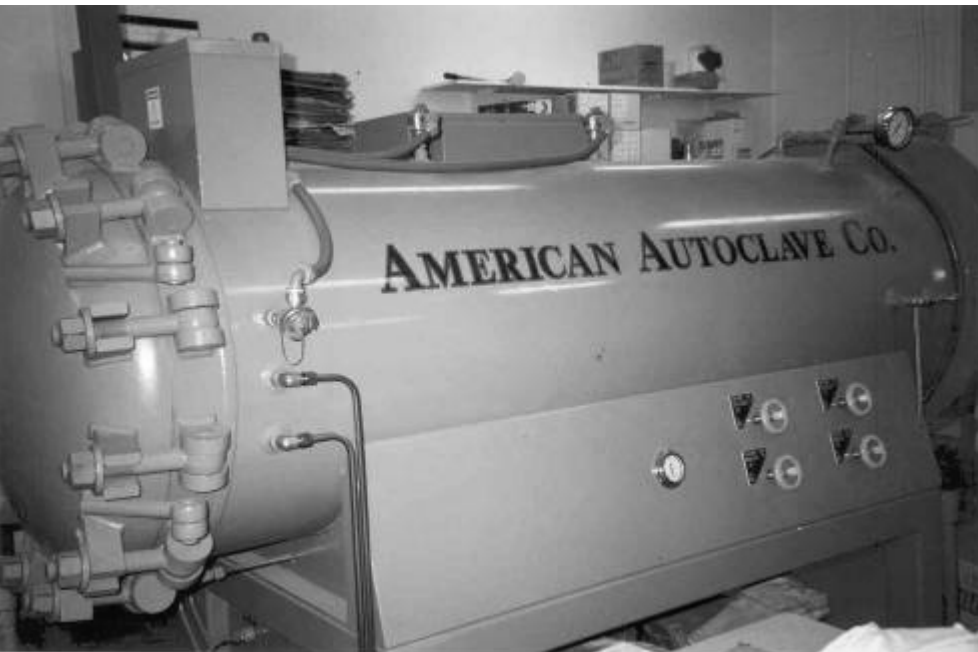

Autoclaves



# DeakinWeek



## Quickstep Technology

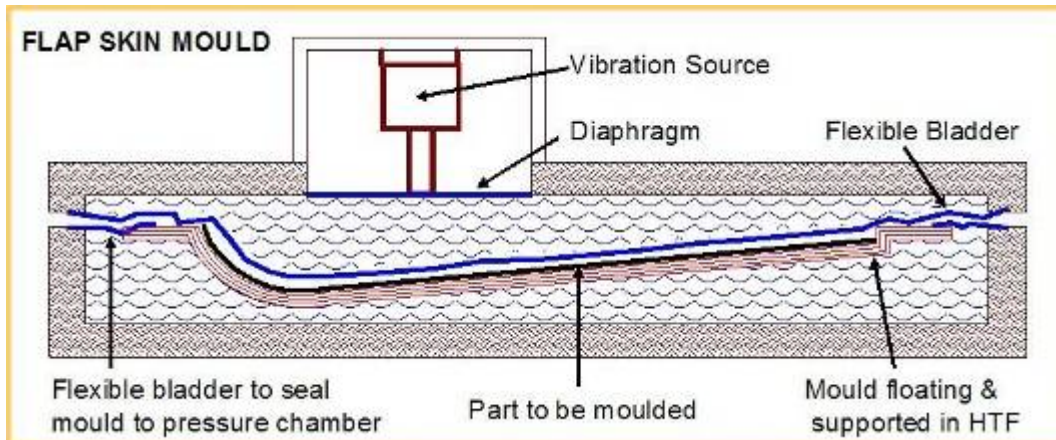
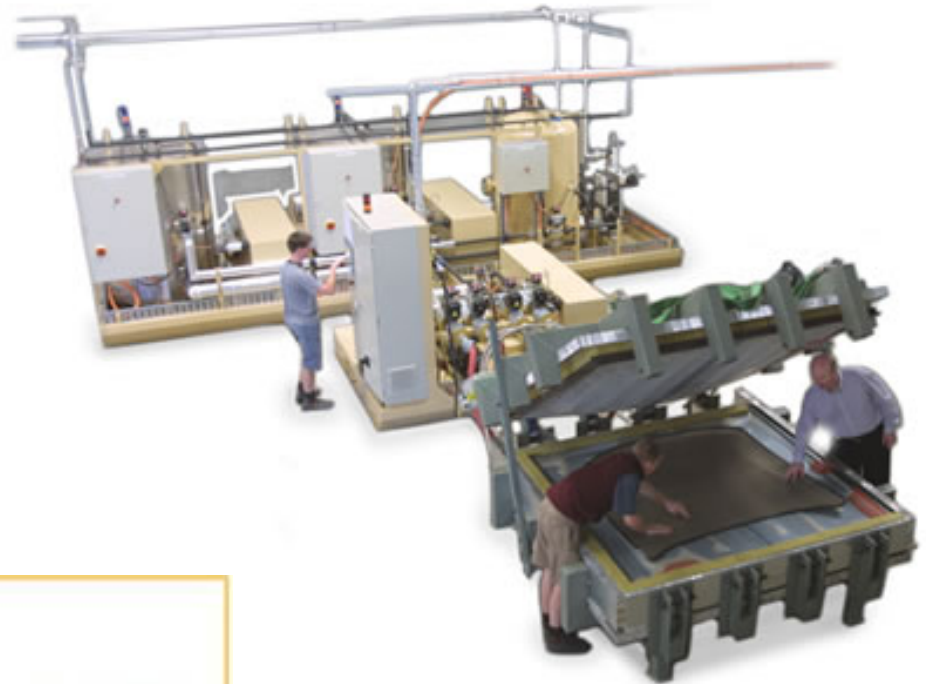



## Quickstep v Autoclave

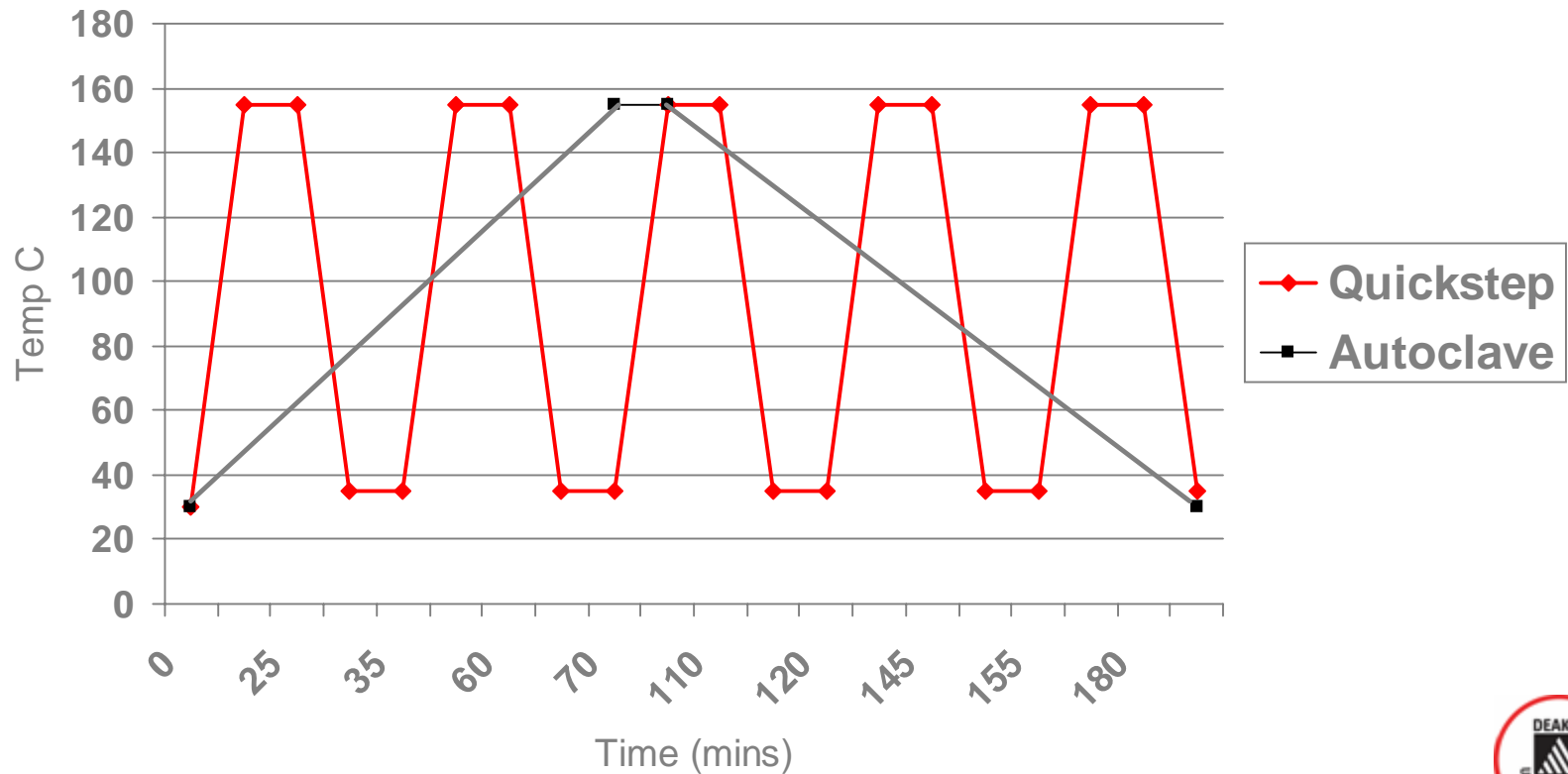



## Key advantages of the Quickstep Process

1. Rapid cure cycles
2. Low pressures
3. Good consolidation achieved (possibly via mechanical vibration).
4. Low infrastructure costs
5. Fewer restrictions on part size.

*Deakin University bought the first computer controlled Quickstep plant in 2003. There are now plants in Manchester, UK, Dayton, Ohio, USA, Toyota, Japan and Munich, Germany.*





## Composites Research at Deakin

- > Helicopter components
- > Melding
- > Crash structures
- > Nanocomposites
- > Surface finish
- > Personal ballistic protection



## Composites Research at Deakin

- > Helicopter components
- > Melding
- > **Crash structures**
- > Nanocomposites
- > Surface finish
- > Personal ballistic protection

# DeakinWeek



Axial compression of tubular profiles is representative of chassis members in a frontal vehicle collision.

Composites afford both reduced vehicle weight and improved crashworthiness.

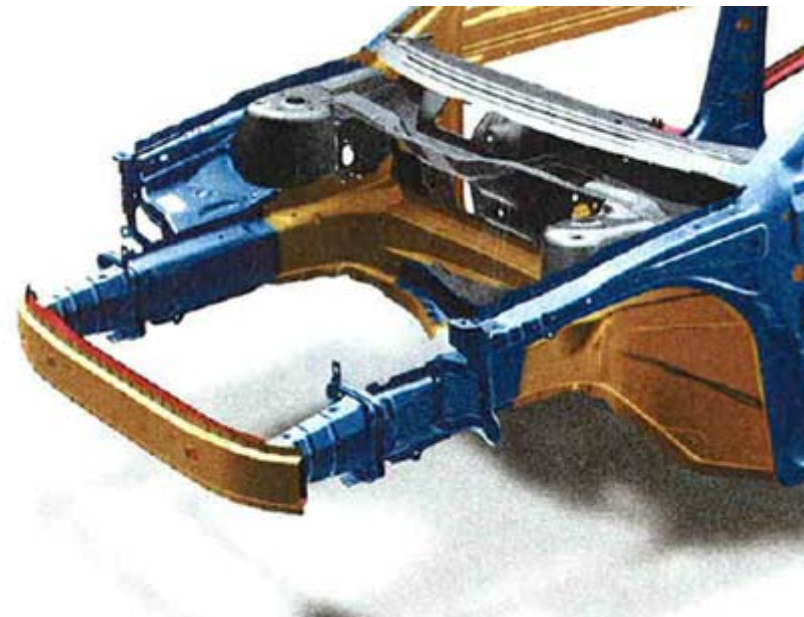

# DeakinWeek

Composites typically possess significantly better crashworthiness characteristics than metallic structures

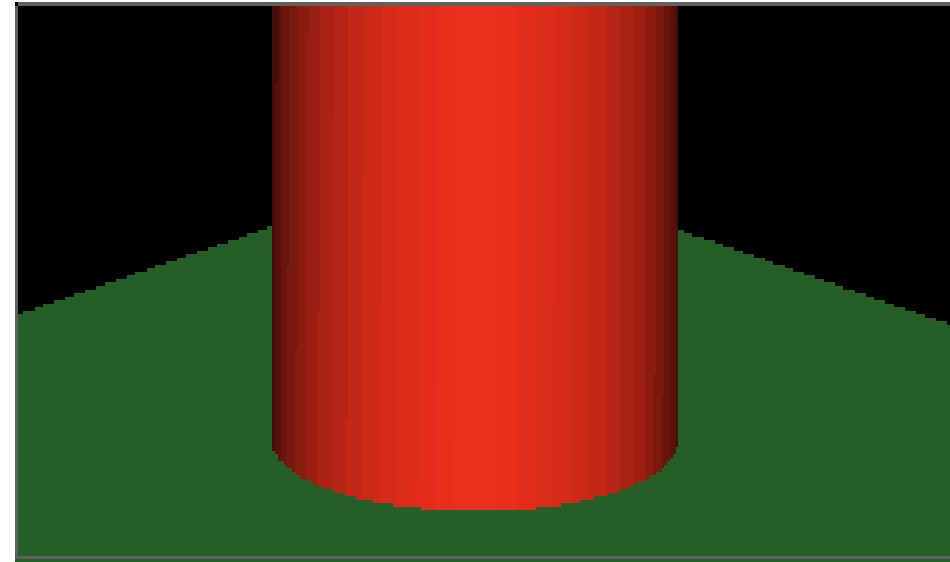

Average SEA figures

- > Aluminium – 20 kJ/kg
- > Mild Steel – 30 kJ/kg

# DeakinWeek



- > A novel method of tube manufacture utilising the Quickstep process has been tested and validated.
- > Heat transfer fluid is pumped through the tube and temperature control is precise due to the low latent heat.

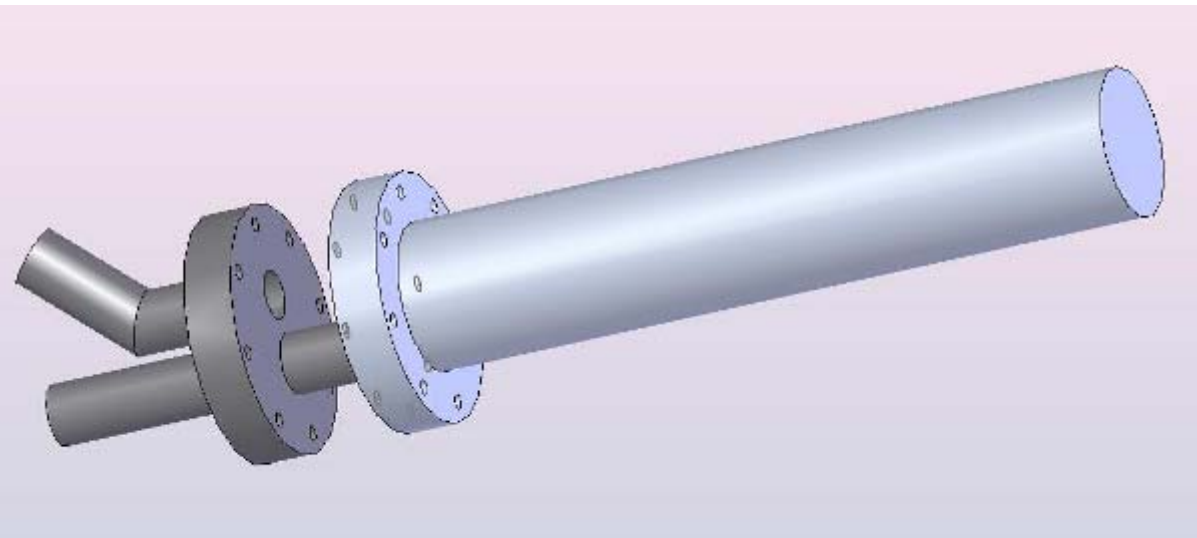

Curing the tube takes just 7 minutes



# DeakinWeek



## > Specific Energy Absorption

~86 kJ/kg (+/- 7)



- > Various production techniques were tested under quasi-static axial crushing loads @ 10mm/min.



## Composites Research at Deakin

- > Helicopter components
- > **Melding**
- > Crash structures
- > Nanocomposites
- > Surface finish
- > Personal ballistic protection



## Melded Joint Schematic

1

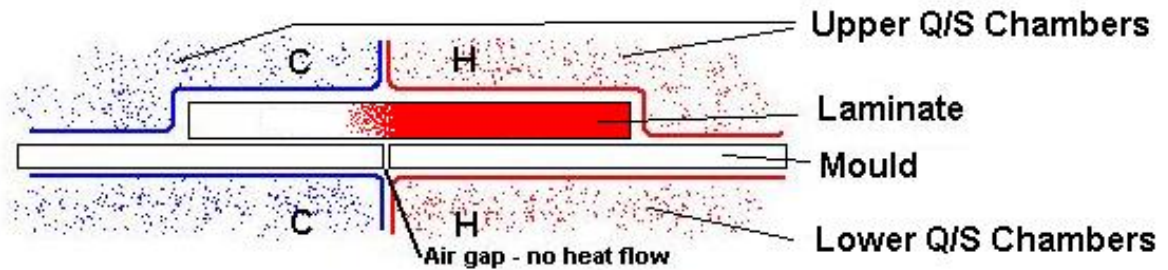

2

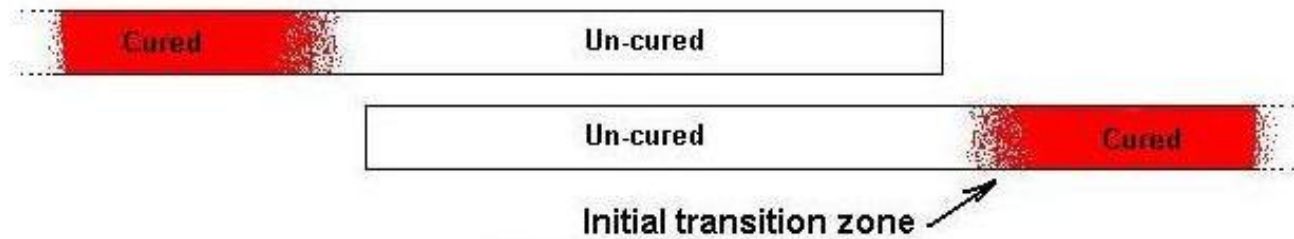

3

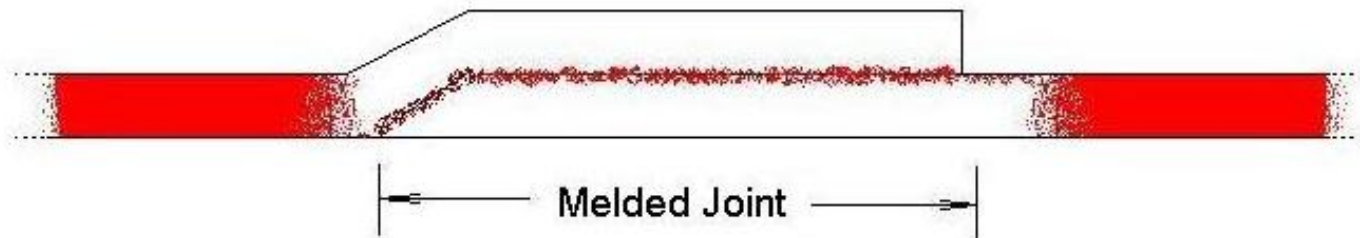

# DeakinWeek

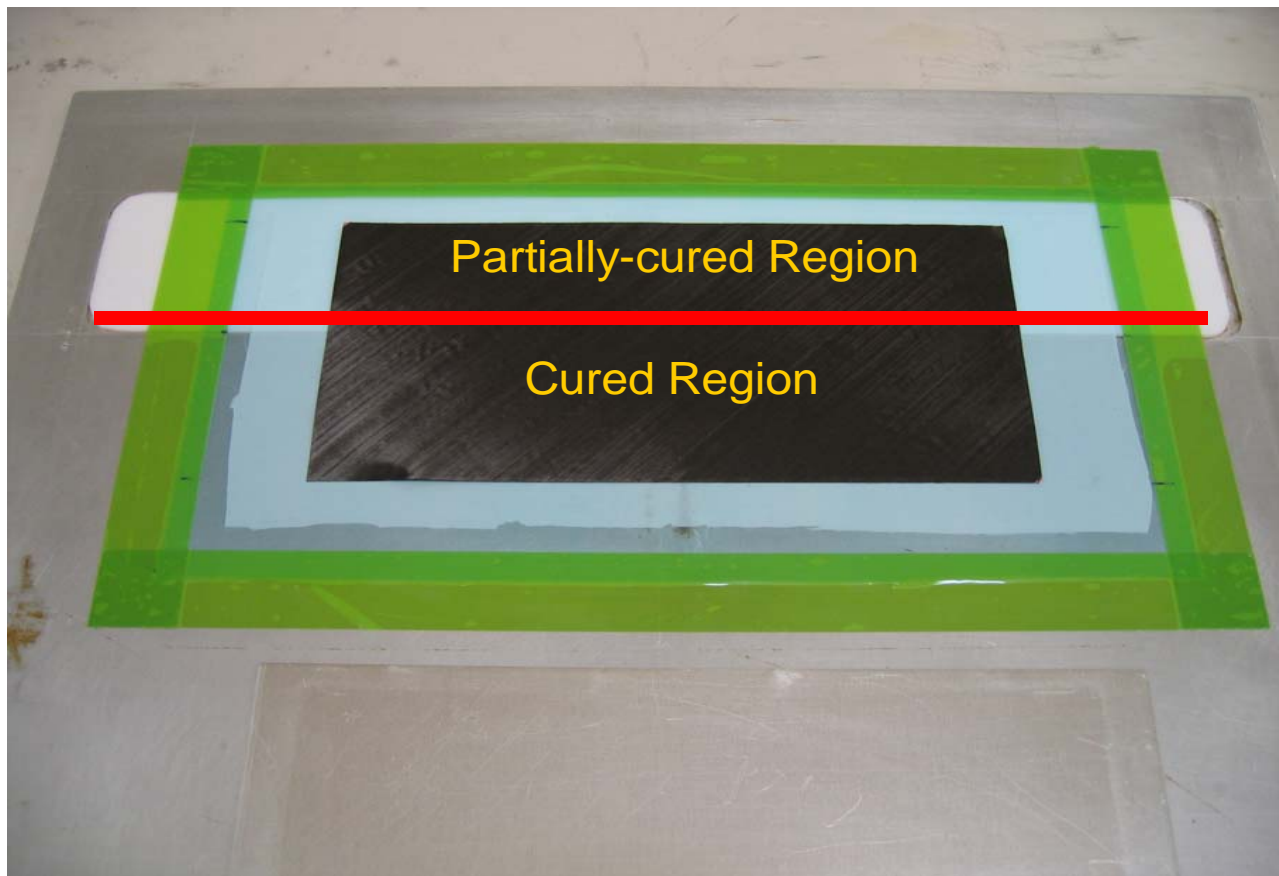

# DeakinWeek



# DeakinWeek

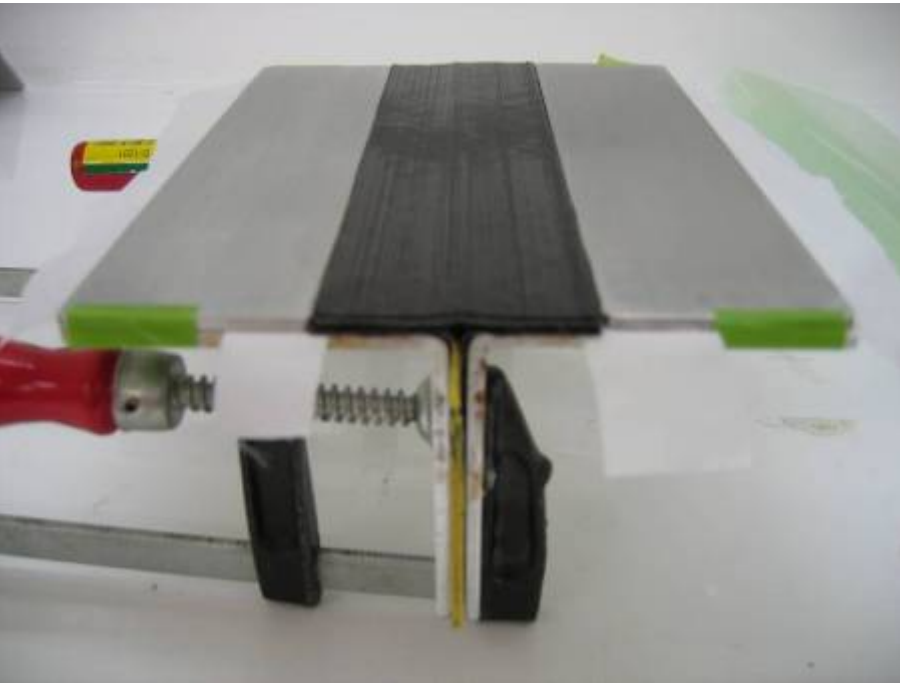

# DeakinWeek



# Melded T-section Deakin Week

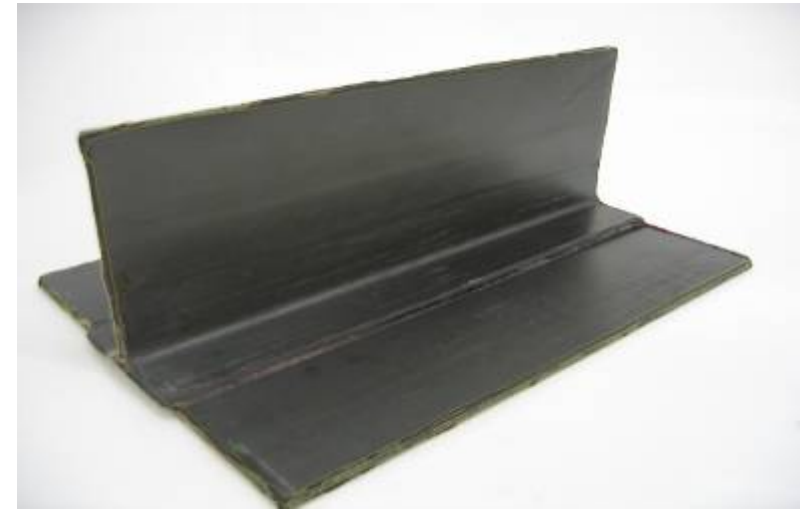
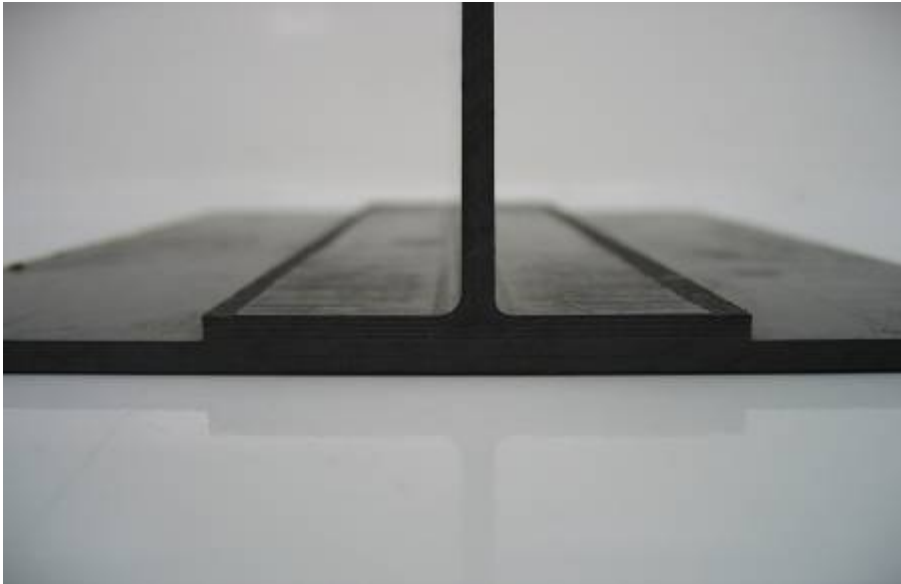

Both adhesively bonded and melded T-sections had similar maximum loads when tested (~4 KN)



# DeakinWeek

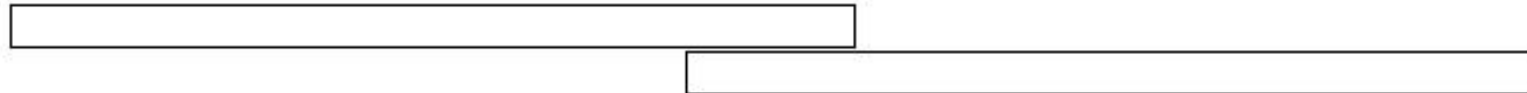

**Monolithic Structure (control sample)**



**Adhesively Bonded**



**Co-cured**

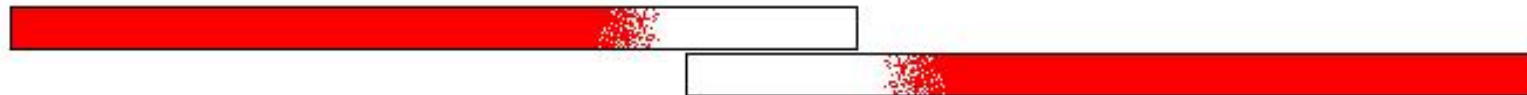

**Melded**



All dimensions as per ASTM D 5868-01



# DeakinWeek

## Lap Shear tests

- > Control sample, Melded and Co-cured samples are all equivalent
- > Perform well compared to a toughened adhesive (Redux 322)

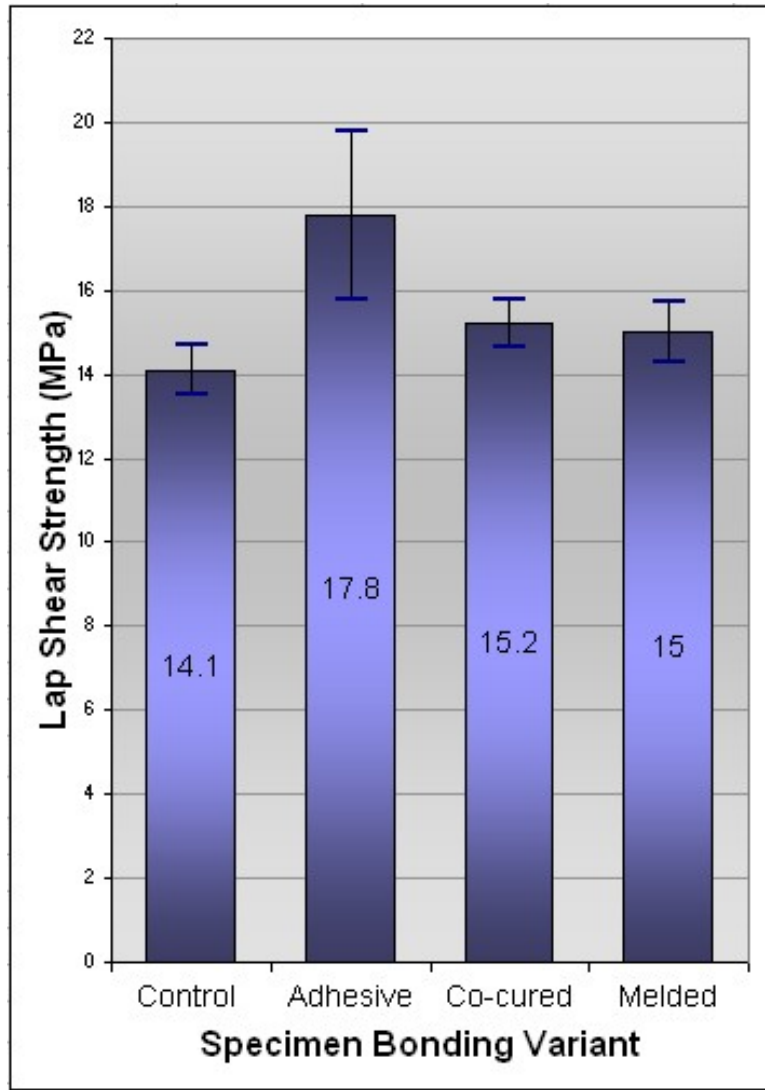



## Boeing Wedge Test

- > Assessment of Environmental durability
  - > A Wedge is inserted into bonded samples
  - > Sample immersed in 45°C water
  - > Crack propagation measured over 2 weeks

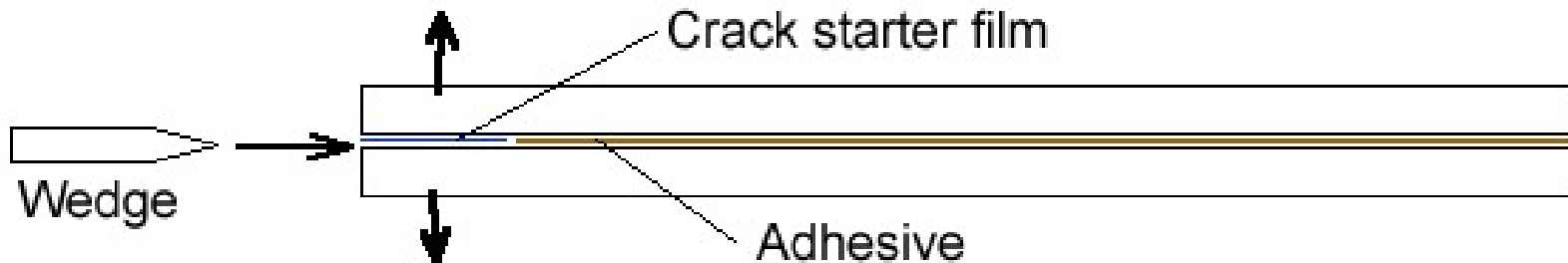

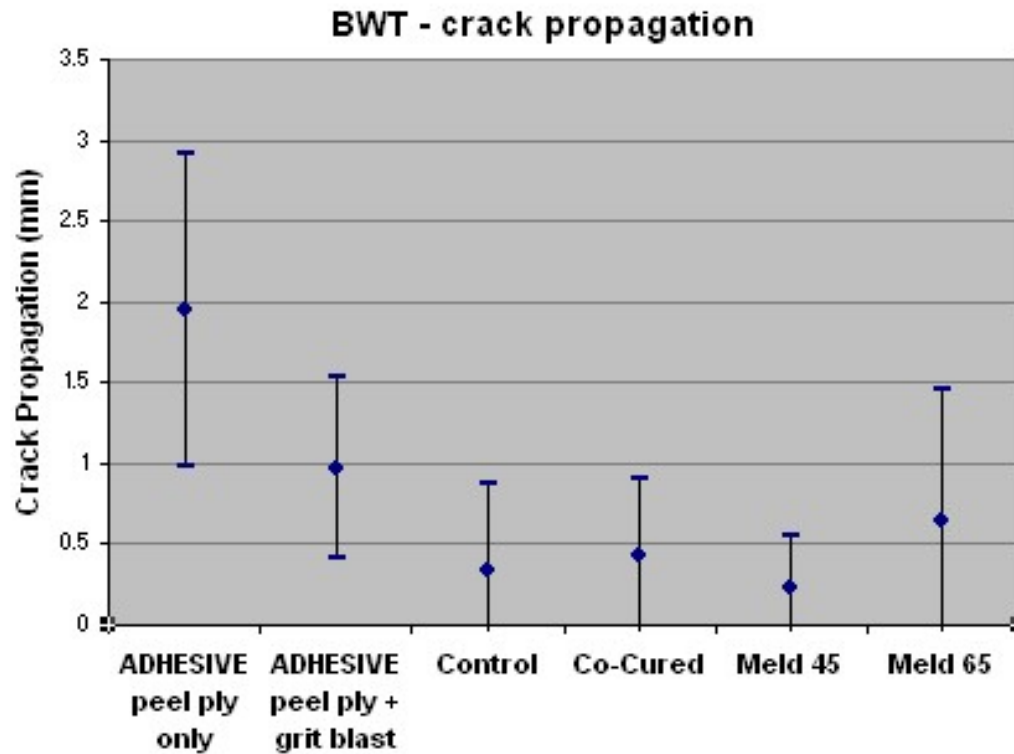

- > Low crack propagation values
  - > Melding equivalent to co-cured and 'all in one' samples

# DeakinWeek



## Melded tubes

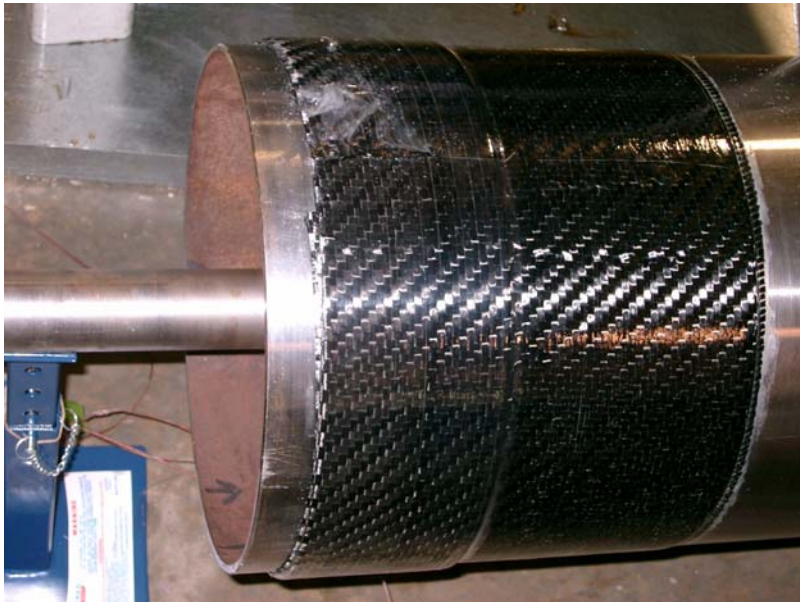

# 787

DREAMLINER

## One Piece Barrel



Boeing is a trademark of Boeing Management Company.  
Copyright © 2005 Boeing. All rights reserved.



***Pressurised to 6,000ft (10,000ft for aluminium aircraft)***

***Increased humidity (reduced dryness)***

***Larger passenger windows***



## Conclusions

- > Carbon fibre composites offer significant advantages in terms of weight savings in aircraft.
- > Weight savings translates to improved fuel efficiency and reduced environmental emissions.
- > The Quickstep process offers a rapid, affordable means of manufacturing composites.



## The Composite Team at Deakin

- > Ben Adamson
- > Steve Agius
- > Aaron Brighton
- > Tim Corbett
- > Ashley Denmead
- > Mark Forrest
- > Claudia Garschke
- > Mandy Herring
- > Abdullah al Kafi
- > Betime Nuhiji
- > Mike Silcock
- > John Vella
- > Jin Zhang

Thanks to:

Prof. A Walker, University of Manchester

